

REV	DATE	BY	DESCRIPTION
-	11-3-2013	PB_Admin	NEW VAULT, NEW REVISION. NOTHING CHANGED. OLD REV WAS C
A	20-12-2013	BS	SCREW CAP DESIGN CHANGED, NEW NUMBER (WITH O-RING) IS E0011495
B	17-11-2015	AvD	ITEM 1 CHANGED: E0044571 WAS E0011497

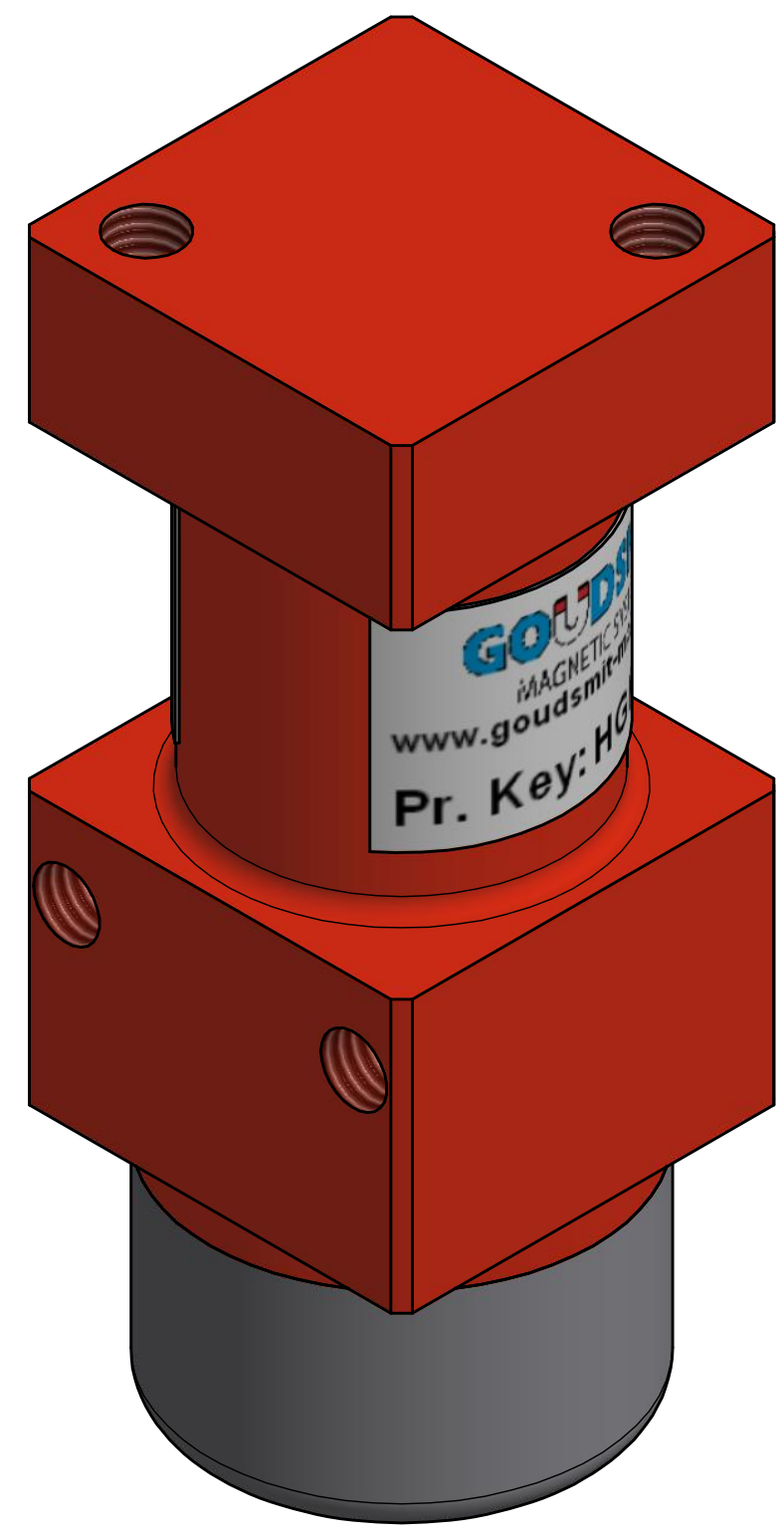

ITEM	QTY	PART NUMBER	DESCRIPTION	Dimensions	
2	1	E0037929	STICKER TPGC024078		
1	1	E0044571	MOUNTING ASSY TPGC024078		
RAW MAT.	QTY	MAT. NUMBER	MAT. DESCRIPTION	LENGTH (mm)	WIDTH (mm)
⊕	1				
Sheet:	A2	Extra info:	MAGNETIC GRIPPER	General tolerance:	ISO 2768 - mK
Drawn:	AvD	Weight (kg):	0,1	Drawn according:	ISO268; ISO1101; ISO2553
Date:	17-11-2015			Status:	Standard
Spare part:	False			Customer reference number:	
Quick search:	TPGC024			File number:	TPGC024078
Description:	HGR-SQ-024-FL-R-M-F			Part number:	TPGC024078
				Rev:	B
				Rev:	B

REV	DATE	BY	DESCRIPTION
E	30-9-2013	RM	REVISION CHANGED CORRESP. MODEL IN VAULT-NOTHING CHANGED
F	2-1-2014	BS	SCREW CAP DESIGN CHANGED, NEW NUMBER (WITH O-RING) IS E0011501
G	24-11-2017	PV	ITEM 3 (PLUG) ADDED

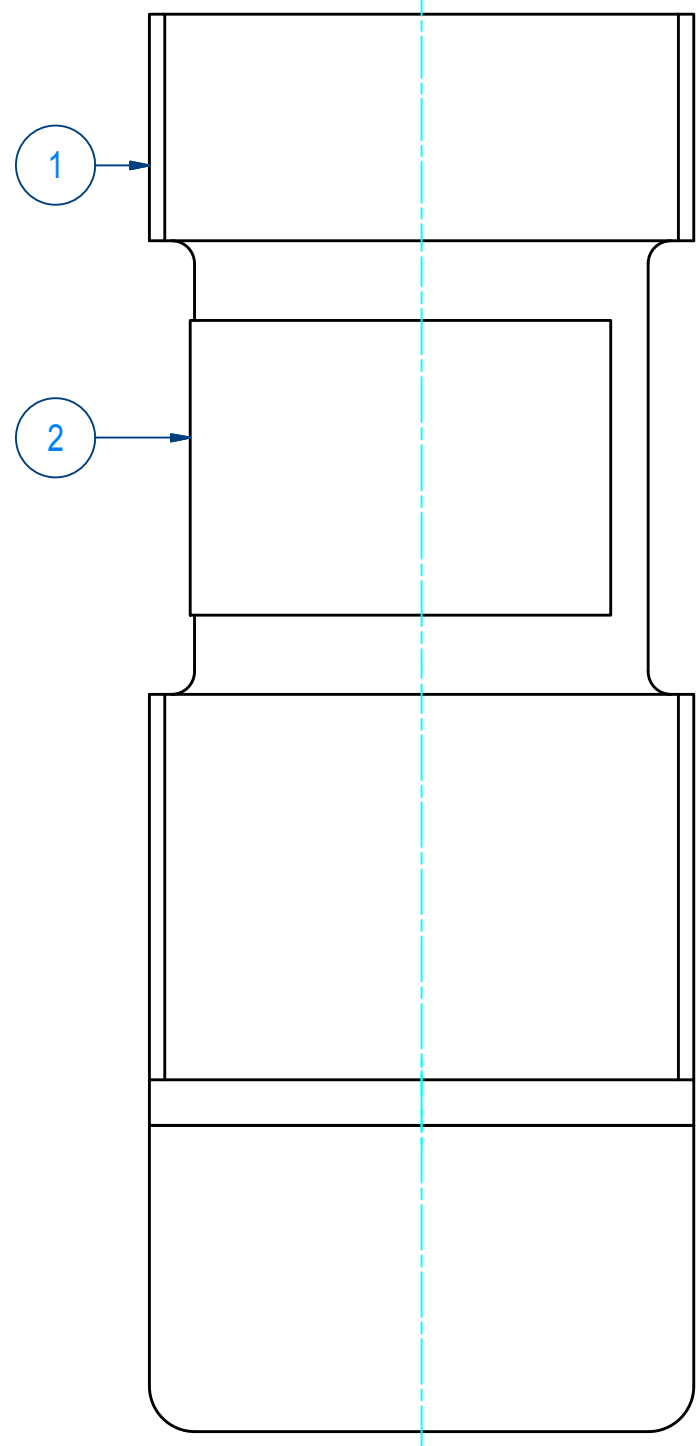
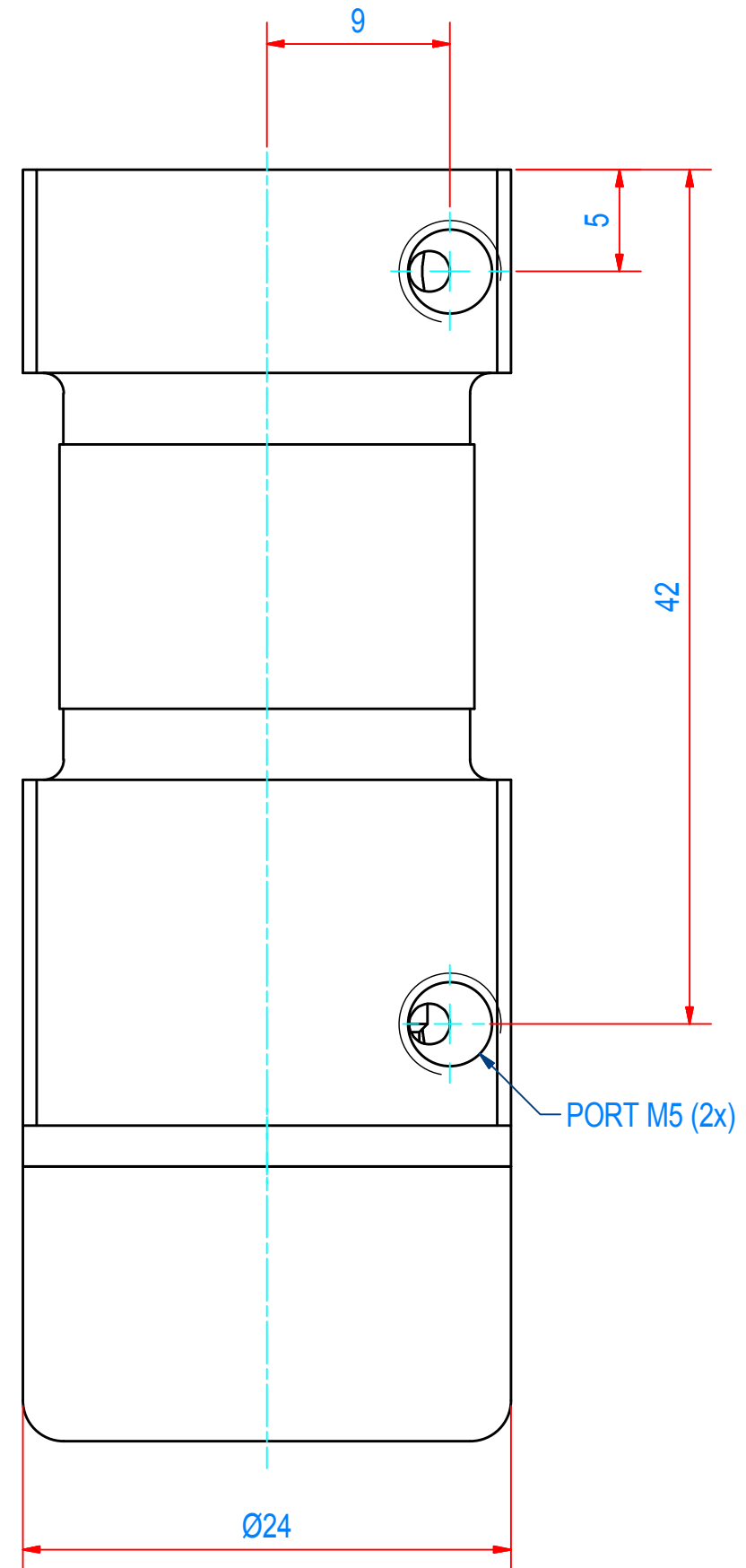
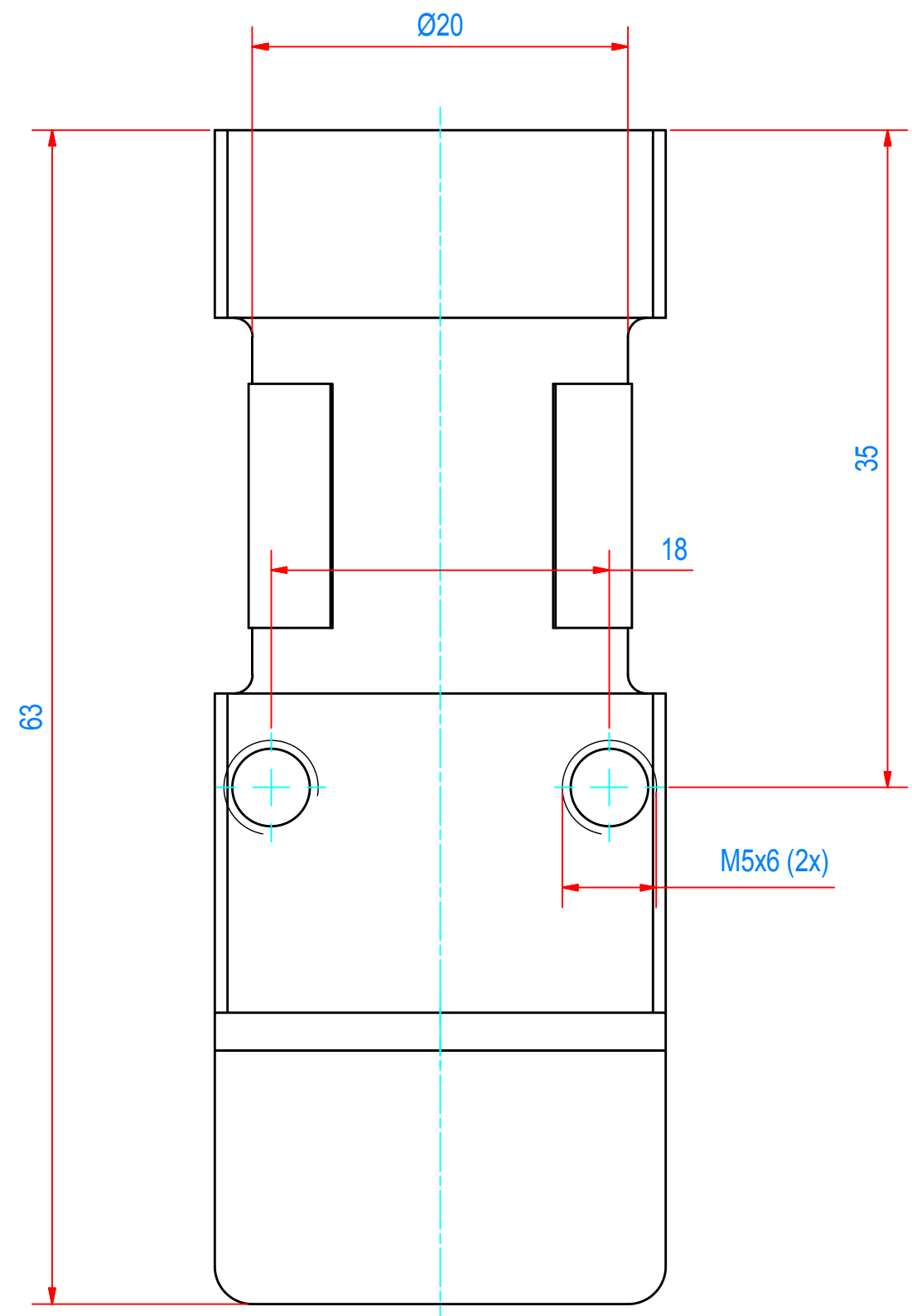
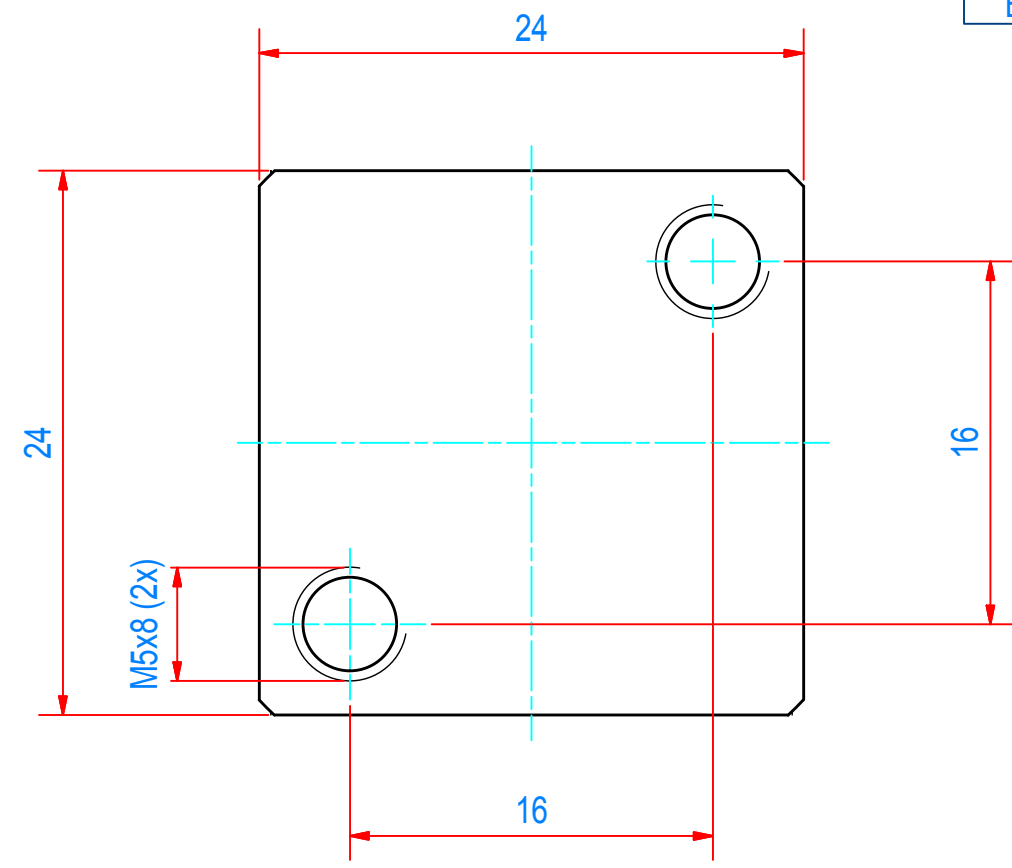
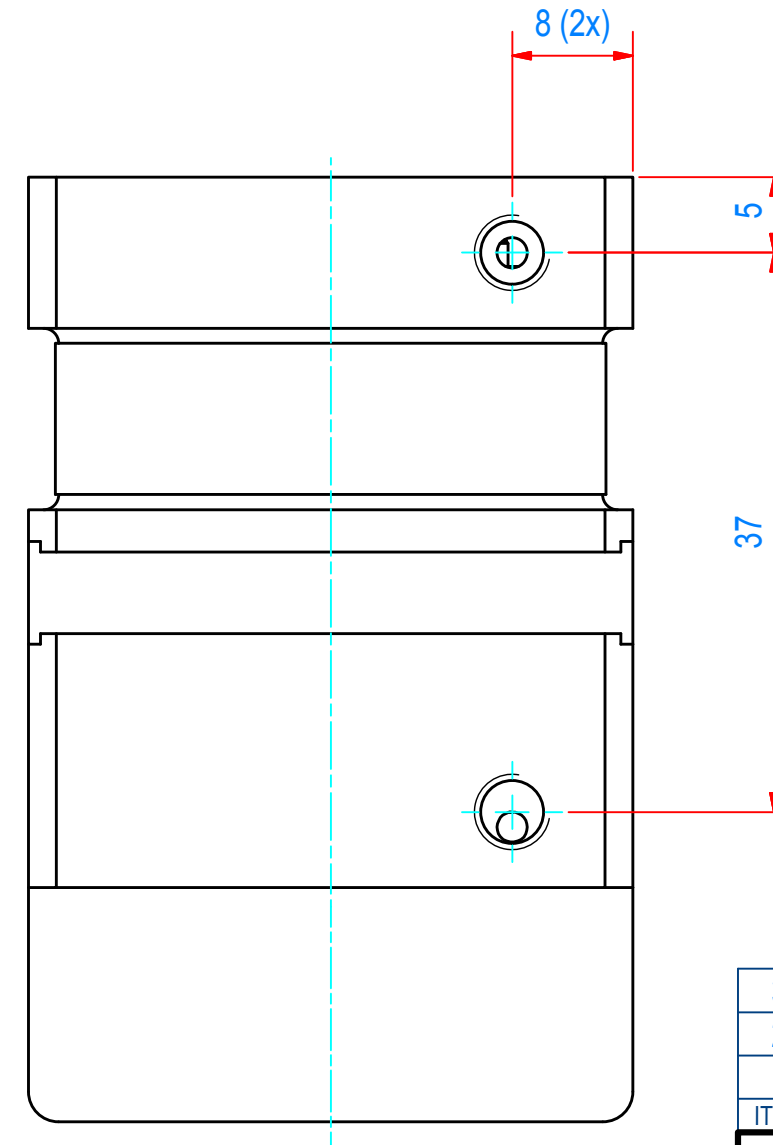
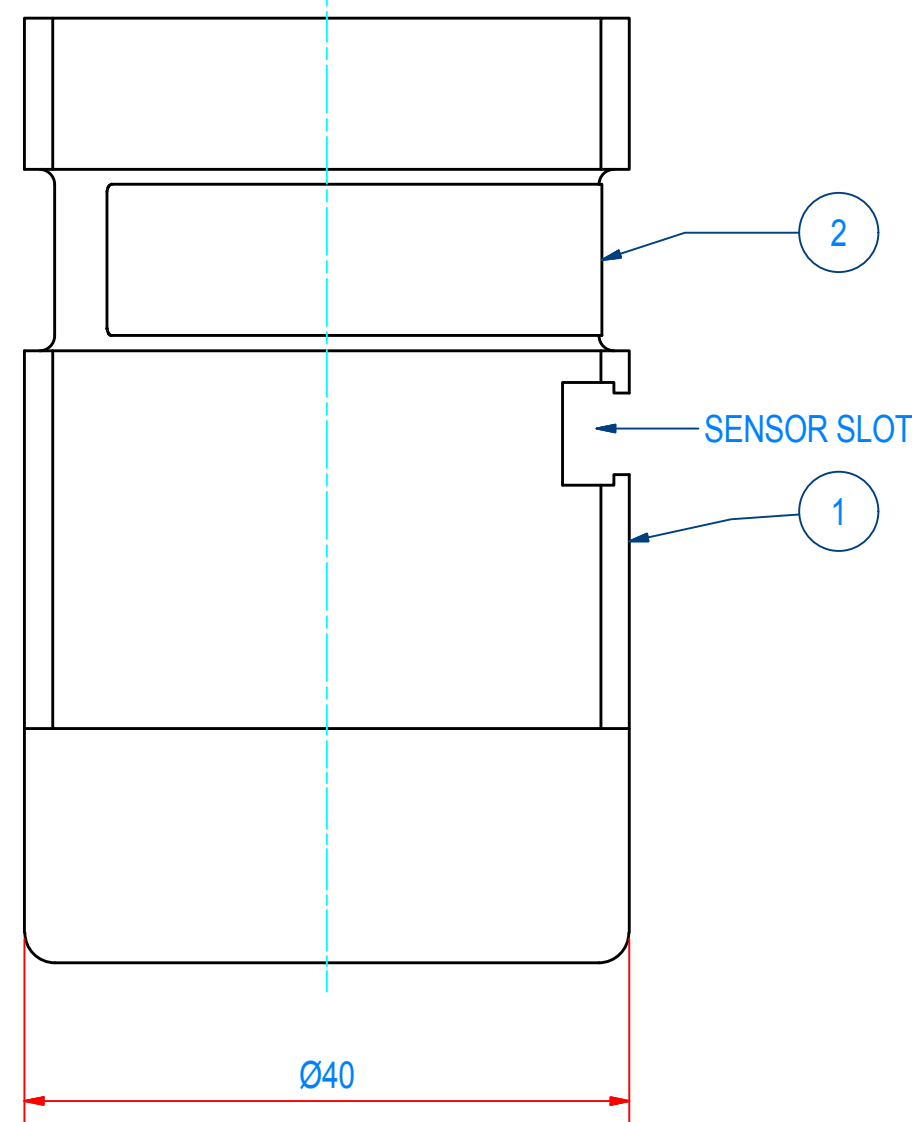
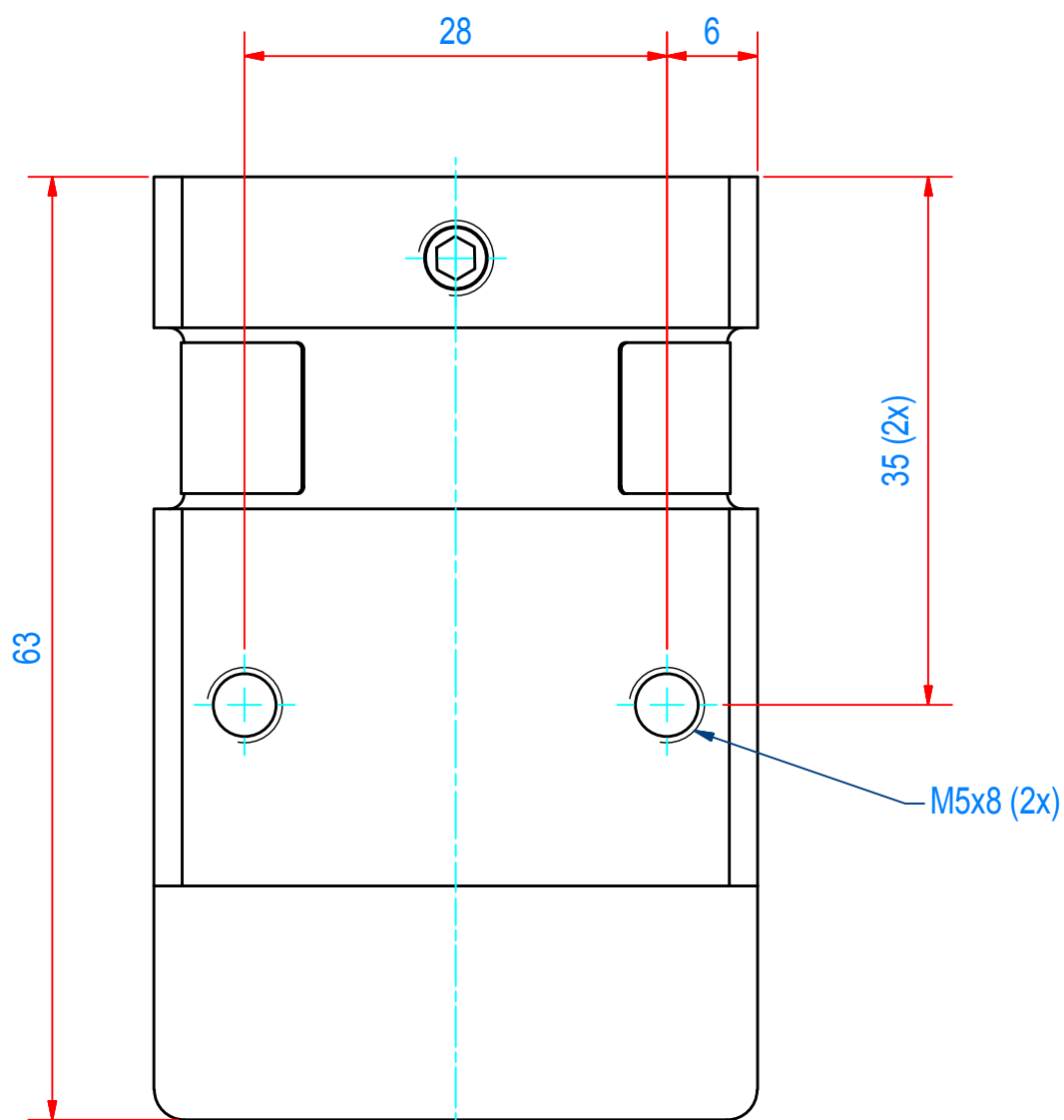
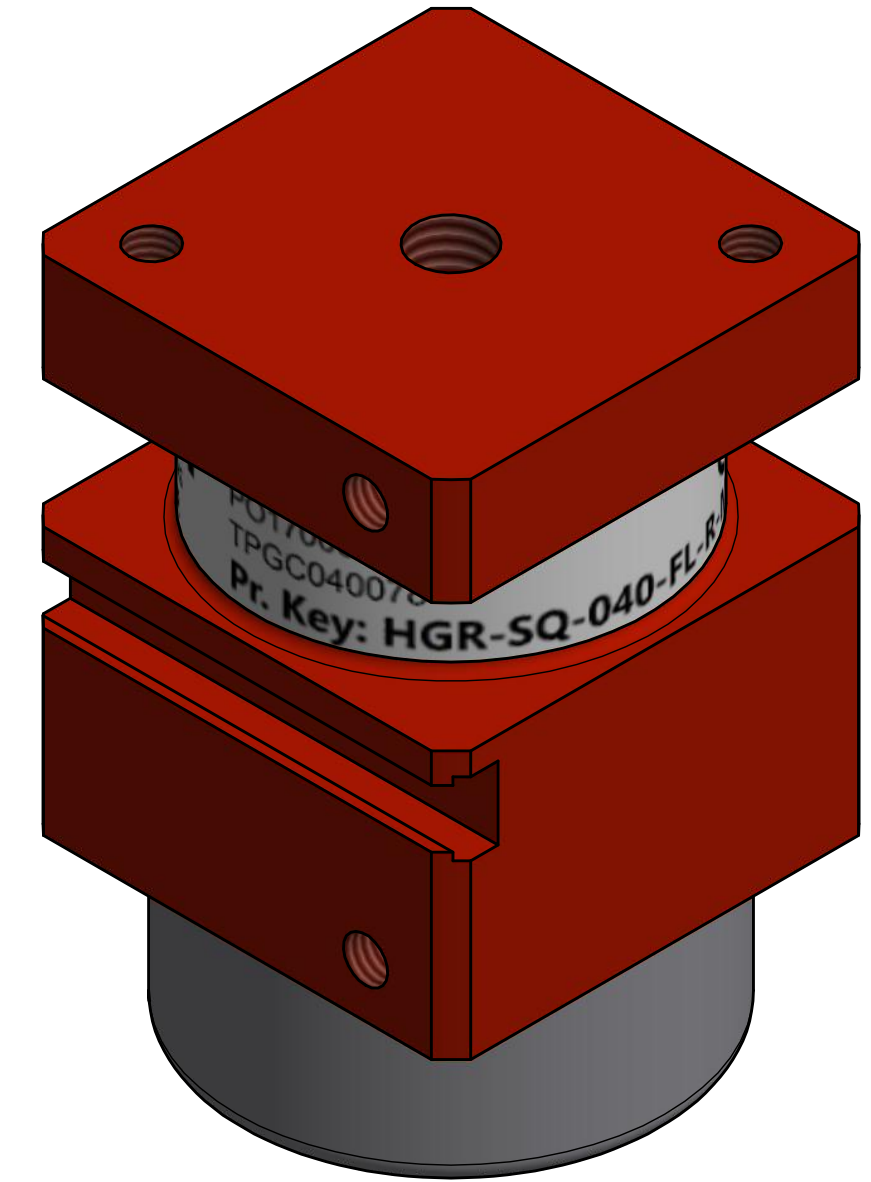
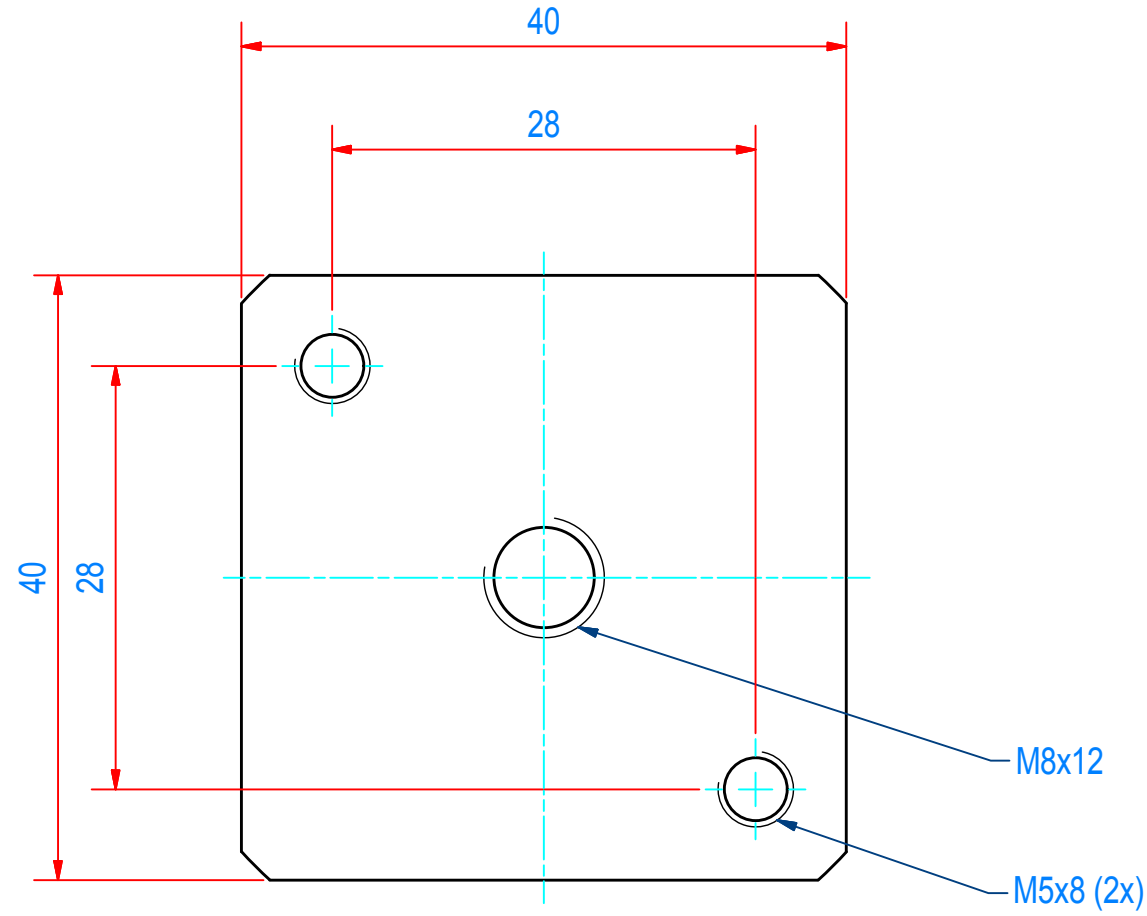

ITEM	QTY	PART NUMBER	DESCRIPTION	Dimensions
3	2	1009.30013	PLUG LDPE M5	
2	1	E0038017	STICKER TPGC040078	
1	1	E0011611	ASSY TPGC040078	

RAW MAT.	Quantity	Material Number	Material Description	Length (mm)	Width (mm)
1	1				

Sheet: A2	Extra info:	General tolerance: ISO 2768 - mK
Drawn: PB	Weight (kg): 0,2	Drawn according: ISO268; ISO1101; ISO2553
Date: 12-2-2009		Status: Standard
Spare part: False		Customer reference number:
Quick search: TPGC040		Document number: E0074045
Description: HGR-SQ-040-FL-R-M-S		Doc.Rev: G
		Part number: TPGC040078
		Rev: G

NEXT STEP
AUTOMATION

(주)넥스텝

Tel. 053-604-3040 Fax. 053-604-3042
Web.nstep.co.kr Mob.010-4488-3040

REV	DATE	BY	DESCRIPTION
-	17-6-2013	BS	NOTHING CHANGED, OLD REVISION B
A	2-1-2014	BS	SCREW CAP DESIGN CHANGED (NEW NUMBER WITH O-RING: E0011622)

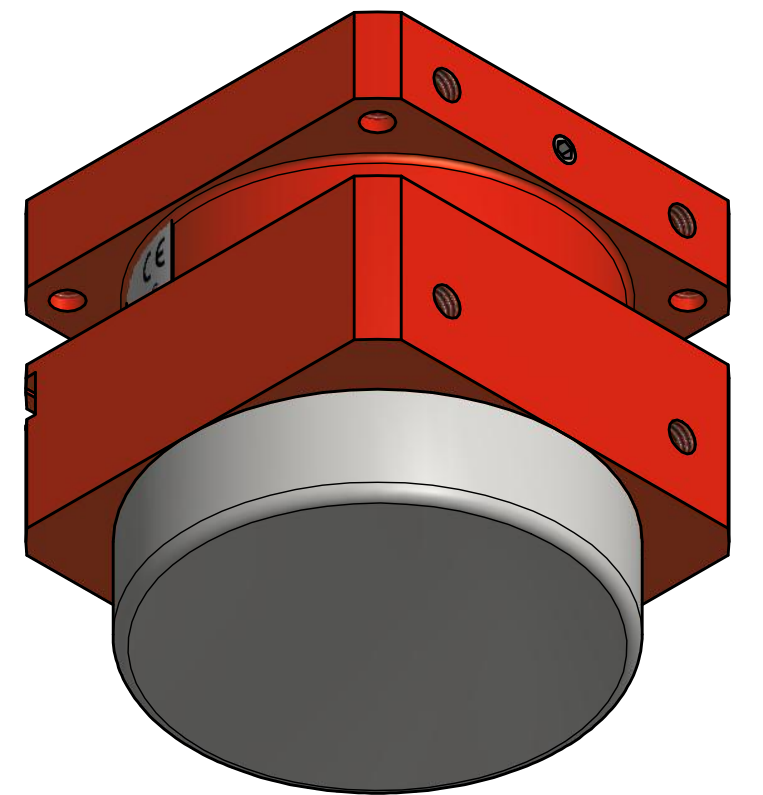
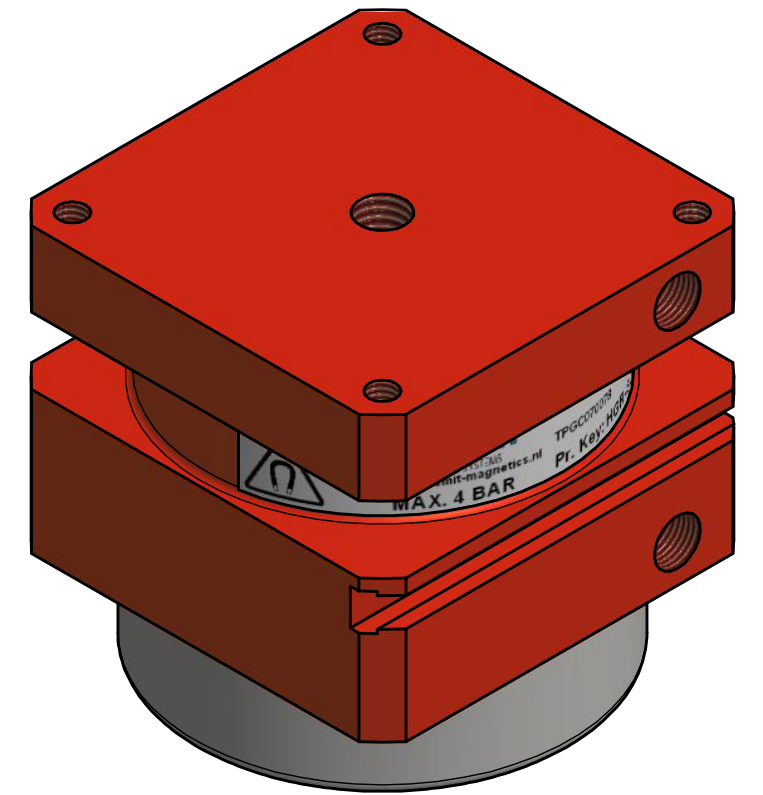
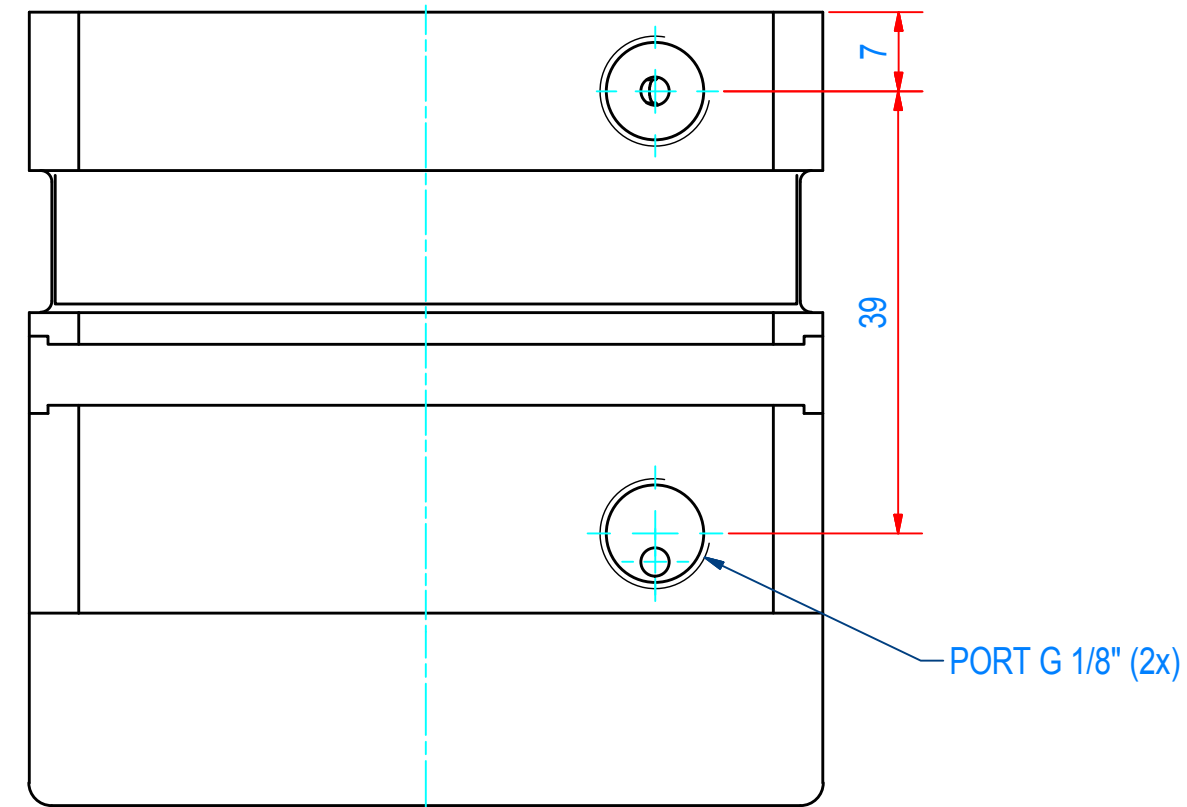
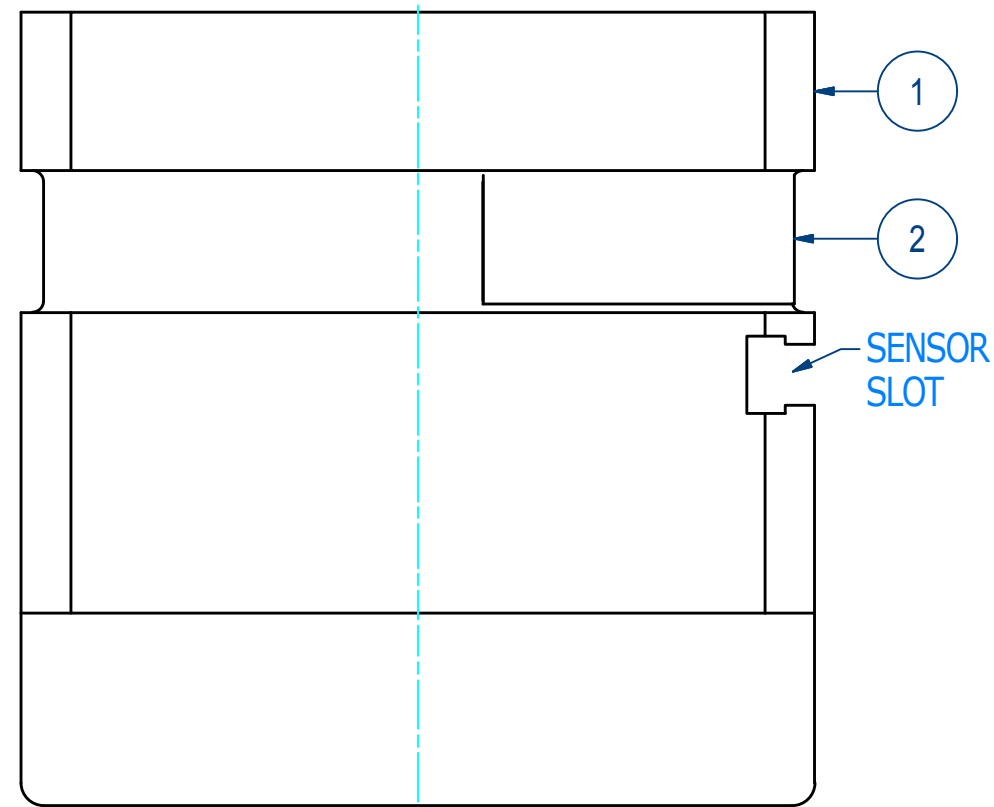
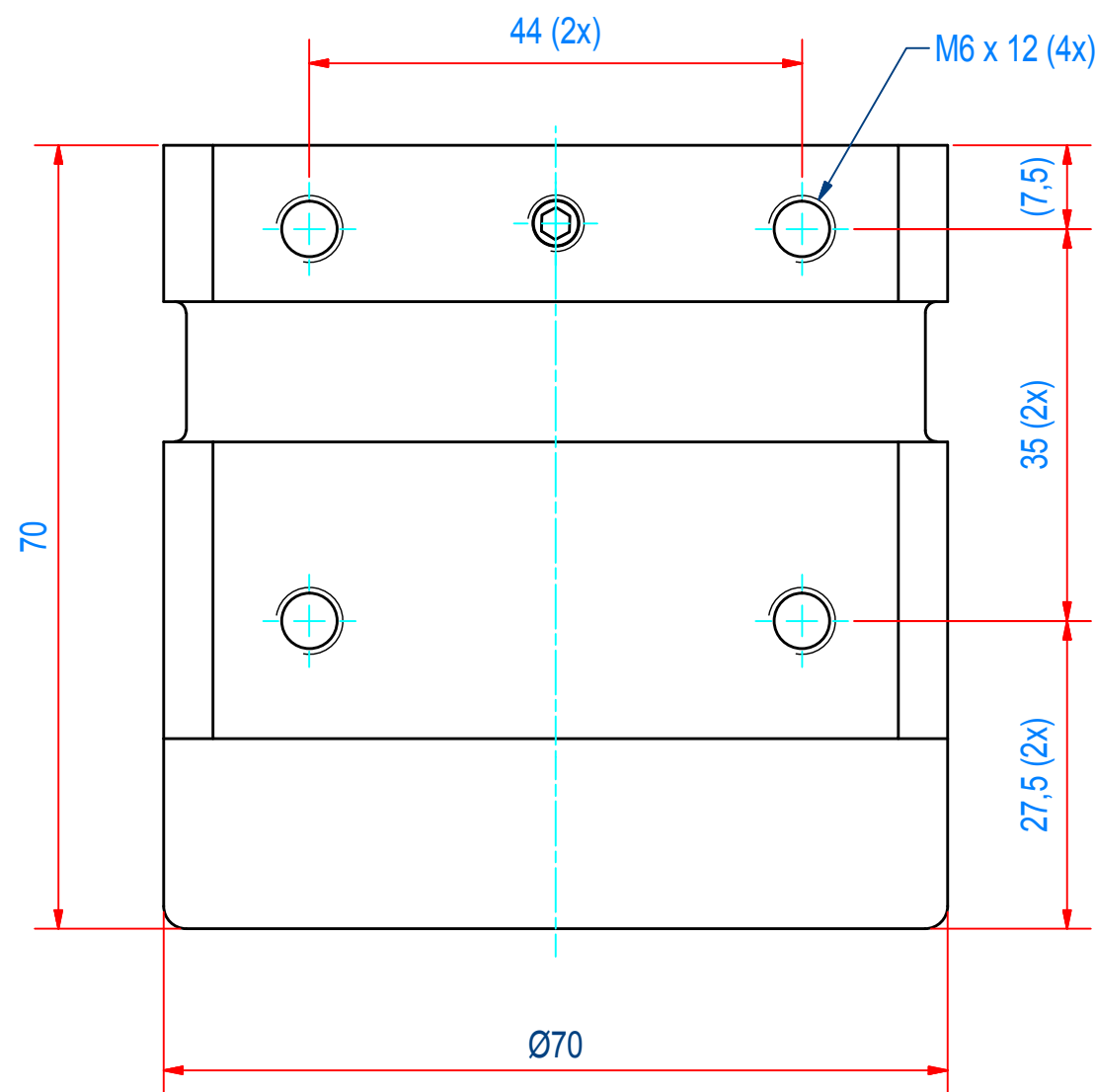
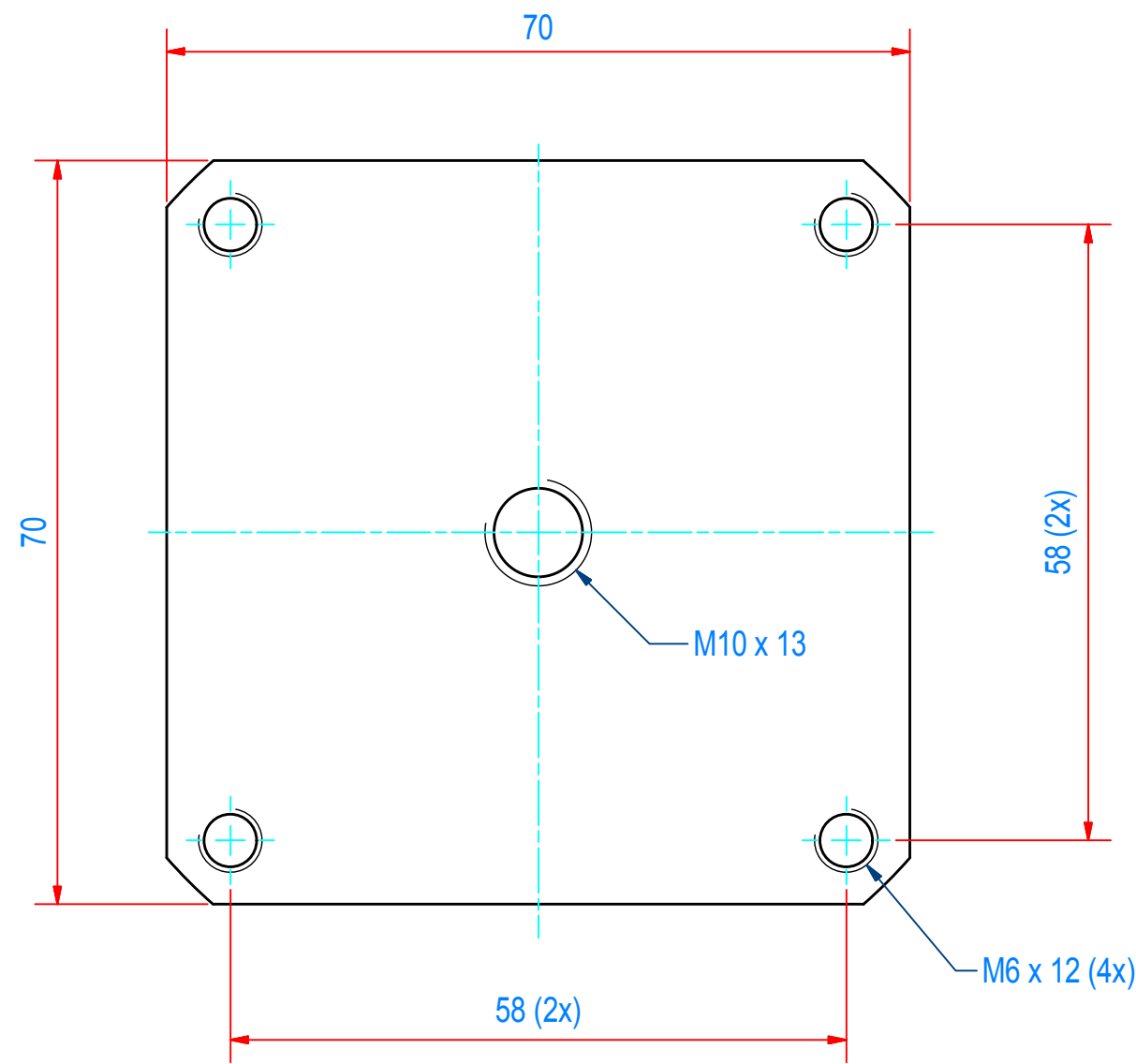

ITEM	QTY	PART NUMBER	DESCRIPTION	Dimensions
2	1	E0038023	STICKER TPGC070078	
1	1	E0011627	MOUNTING ASSY TPGC070	
RAW MAT.	QTY	MAT. NUMBER	MAT. DESCRIPTION	LENGTH (mm) WIDTH (mm)
⊕	Sheet: A2	Extra info:	General tolerance: ISO 2768- mK	
Drawn: BS	Weight (kg): 0,8		Drawn according: ISO268; ISO1101; ISO2553	
Date: 17-6-2013			Status: Standard	
Spare part: False			Customer reference number:	
Quick search: TPGC070			File number: TPGC070078	Rev: A
Description: HGR-SQ-070-FL-R-G-S			Part number: TPGC070078	Rev: A

GOUDSMIT
MAGNETIC SYSTEMS

© All rights reserved. Reproduction is not permitted without written permission of GOUDSMIT Magnetic Systems BV

NEXT STEP
AUTOMATION

(주)넥스텝

Tel. 053-604-3040 Fax. 053-604-3042
Web.nstep.co.kr Mob.010-4488-3040

REV	DATE	BY	DESCRIPTION
-	6-5-2013	BS	NOTHING CHANGED, OLD REVISION C
A	6-1-2014	BS	SCREW CAP DESIGN CHANGED, NEW NUMBER WITH O-RING: E0011674

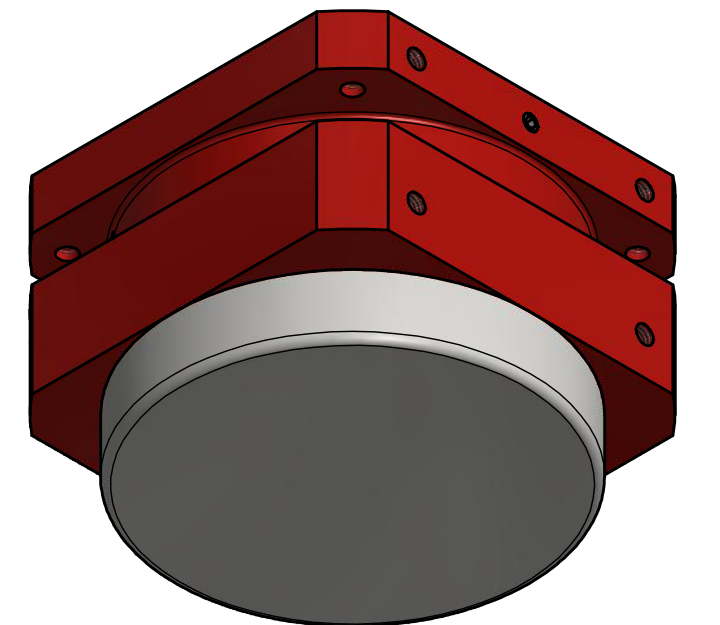
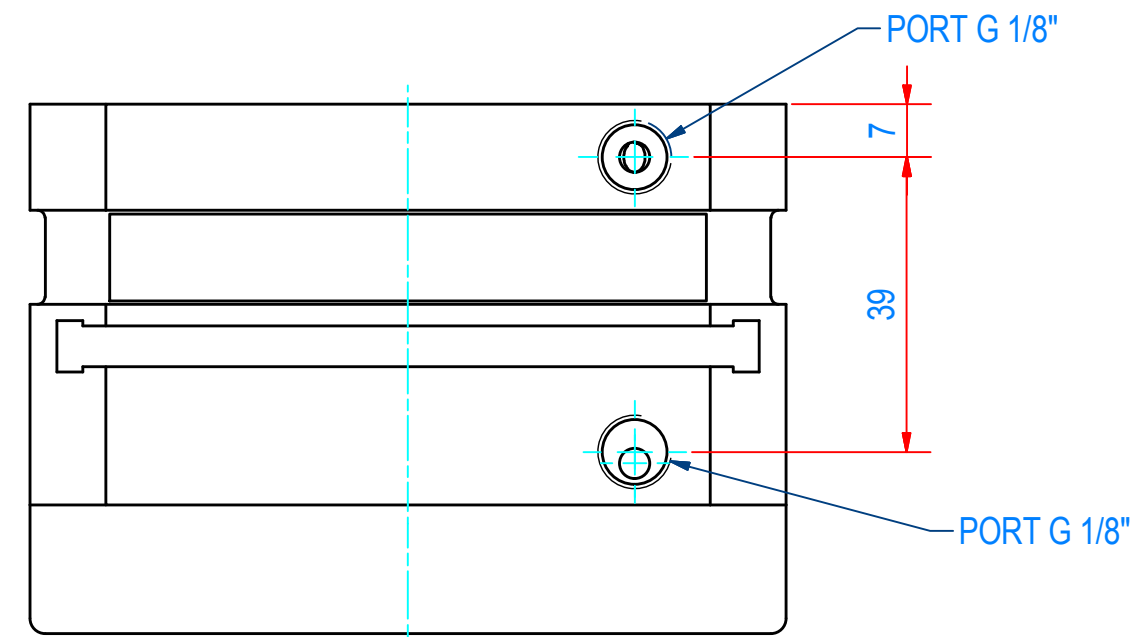
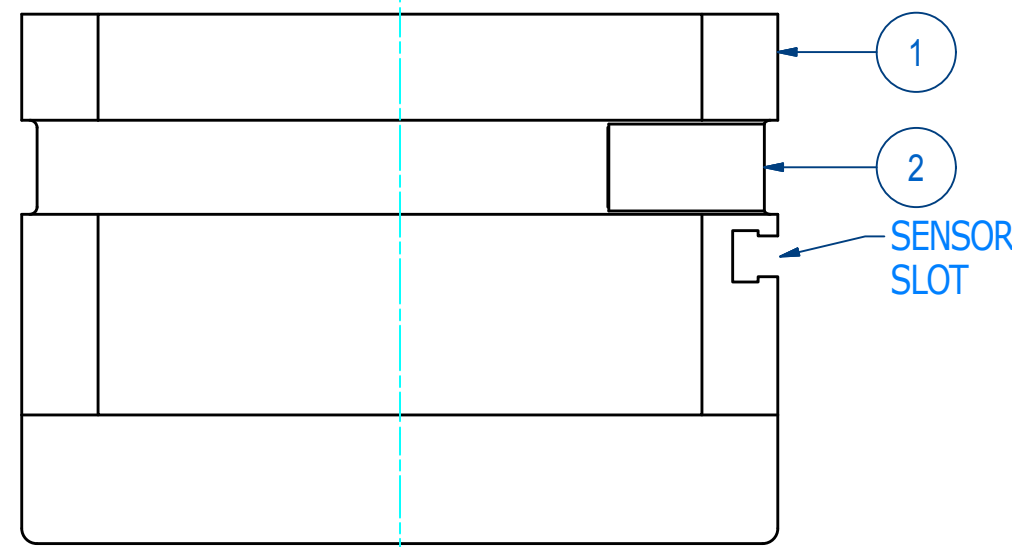
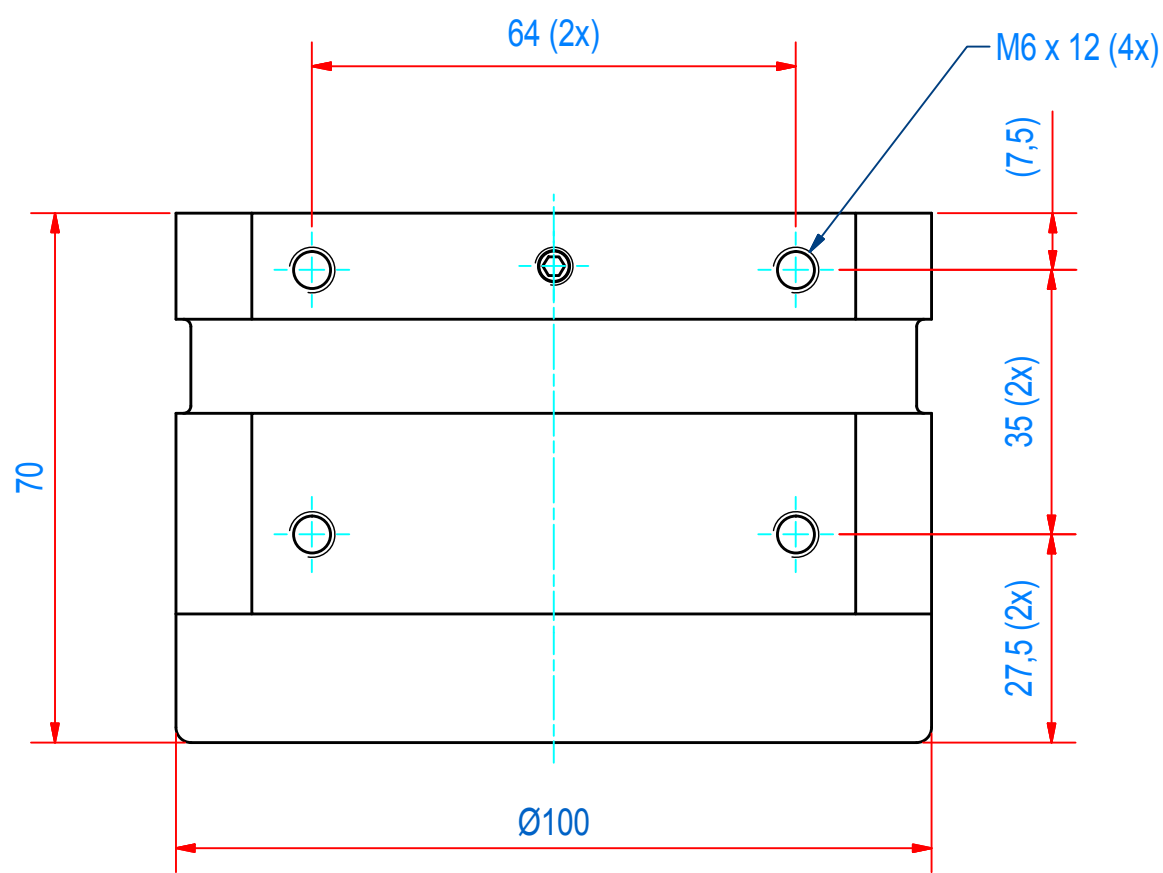
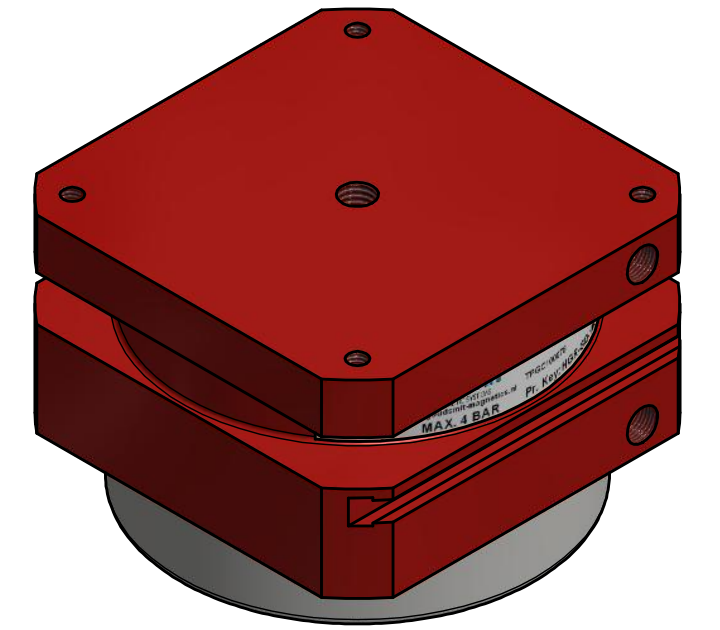
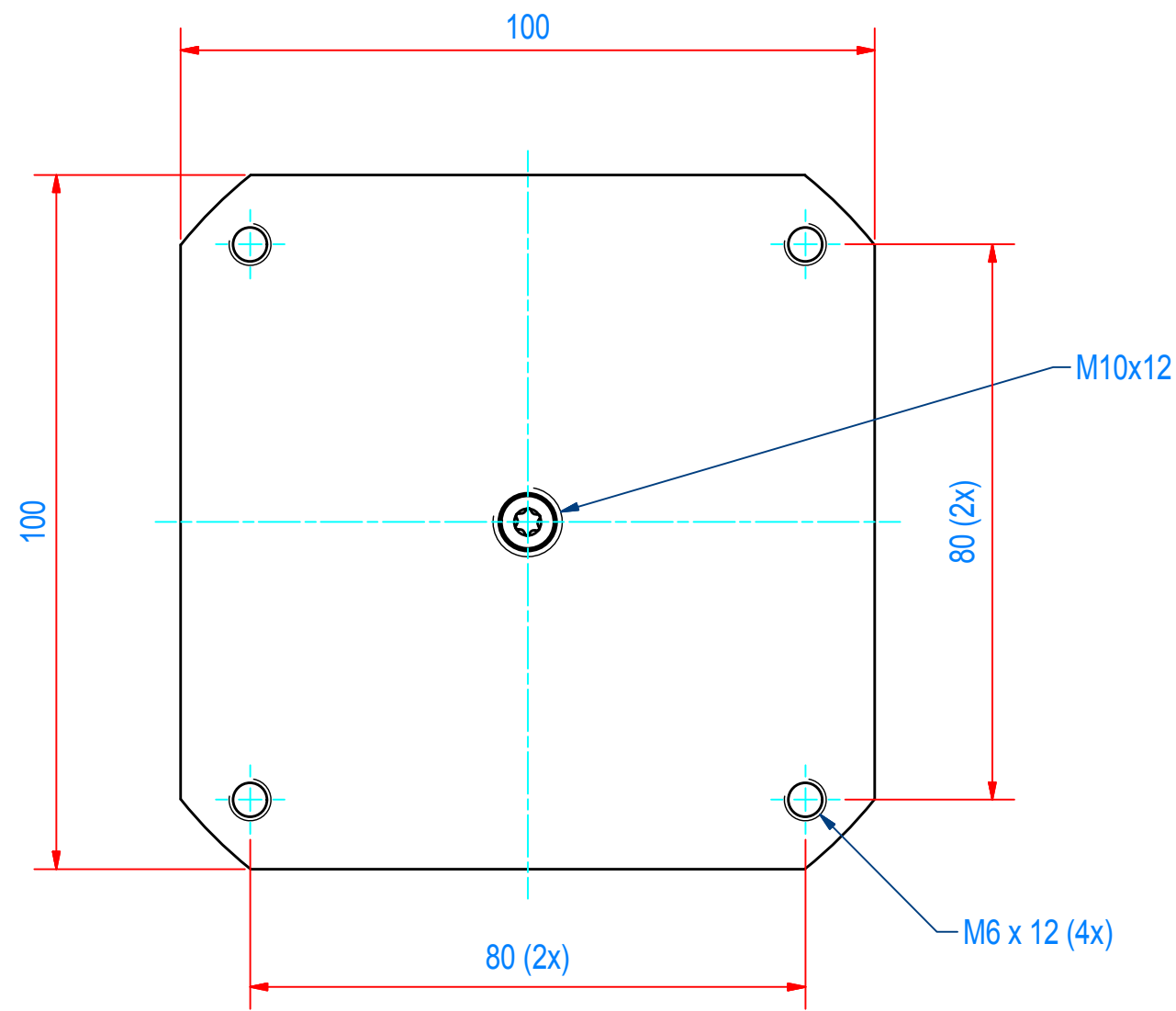

ITEM	QTY	PART NUMBER	DESCRIPTION	Dimensions
2	1	E0038028	STICKER TPGC100078	
1	1	E0011675	MOUNTING ASSY	
RAW MAT.	QTY	MAT. NUMBER	MAT. DESCRIPTION	LENGTH (mm) WIDTH (mm)
1	1			

Sheet: A2	Extra info:	General tolerance: ISO 2768- mK
Drawn: BS	Weight (kg): 1,5	Drawn according: ISO268; ISO1101; ISO2553
Date: 6-5-2013		Status: Standard
Spare part: False		Customer reference number:
Quick search: TPGC100	 <small>© All rights reserved. Reproduction is not permitted without written permission of GOUDSMIT Magnetic Systems BV</small>	File number: TPGC100078 Rev: A
Description: HGR-SQ-100-FL-R-G-S		Part number: TPGC100078 Rev: A

REV	DATE	BY	DESCRIPTION
-	8-4-2013	PB	NEW VAULT, NEW REVISION. NOTHING CHANGED. OLD REV WAS D
A	24-6-2015	AvD	E0034158 WAS A190523 (REDESIGN, HEIGHT 104 WAS 94)
B	1-7-2015	AvD	O-RING DELETED FROM BOTTOM

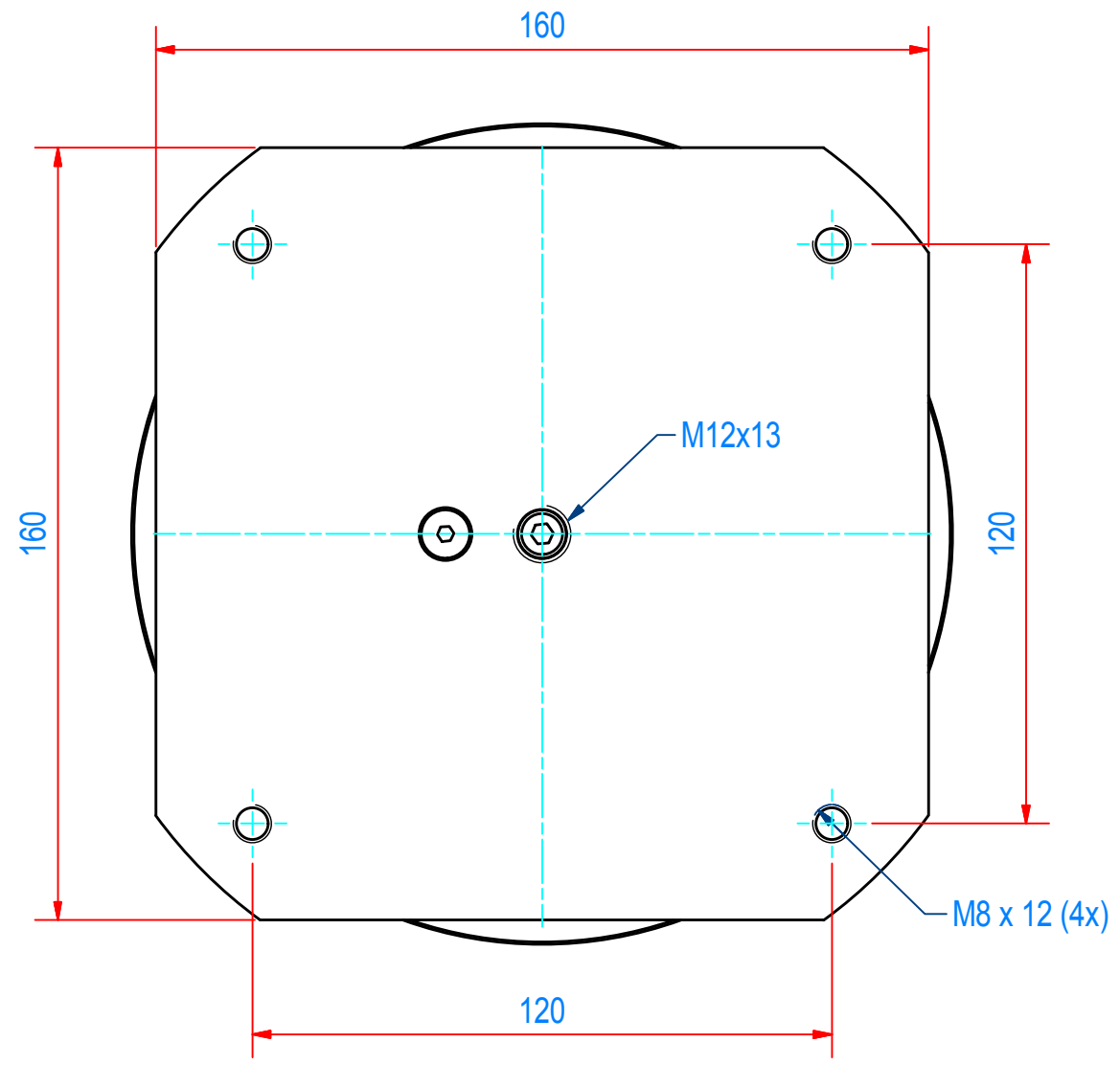

USE PUN-E-8x1 HOSE

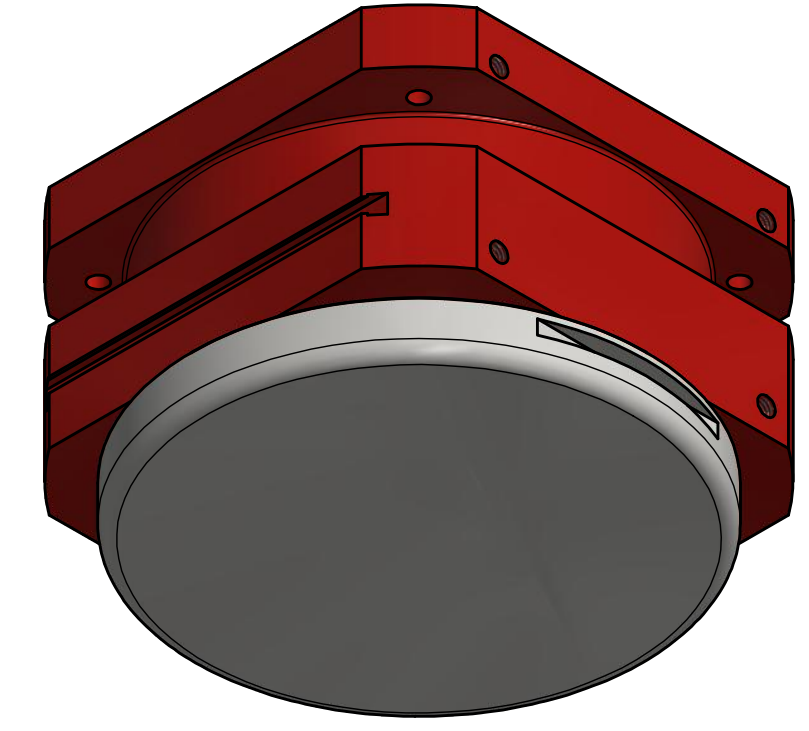
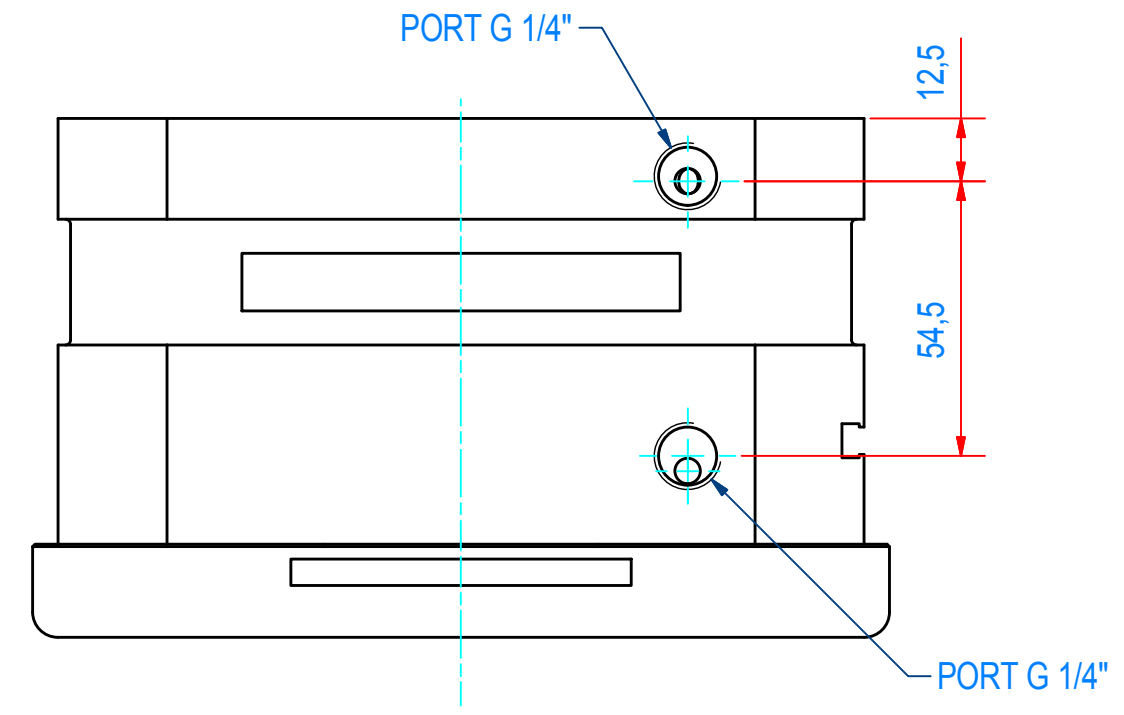
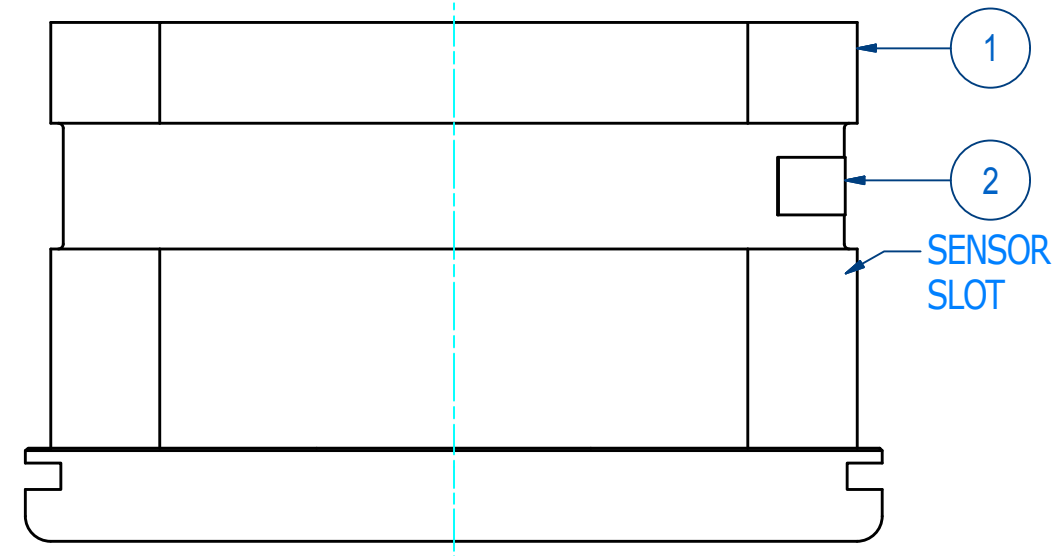
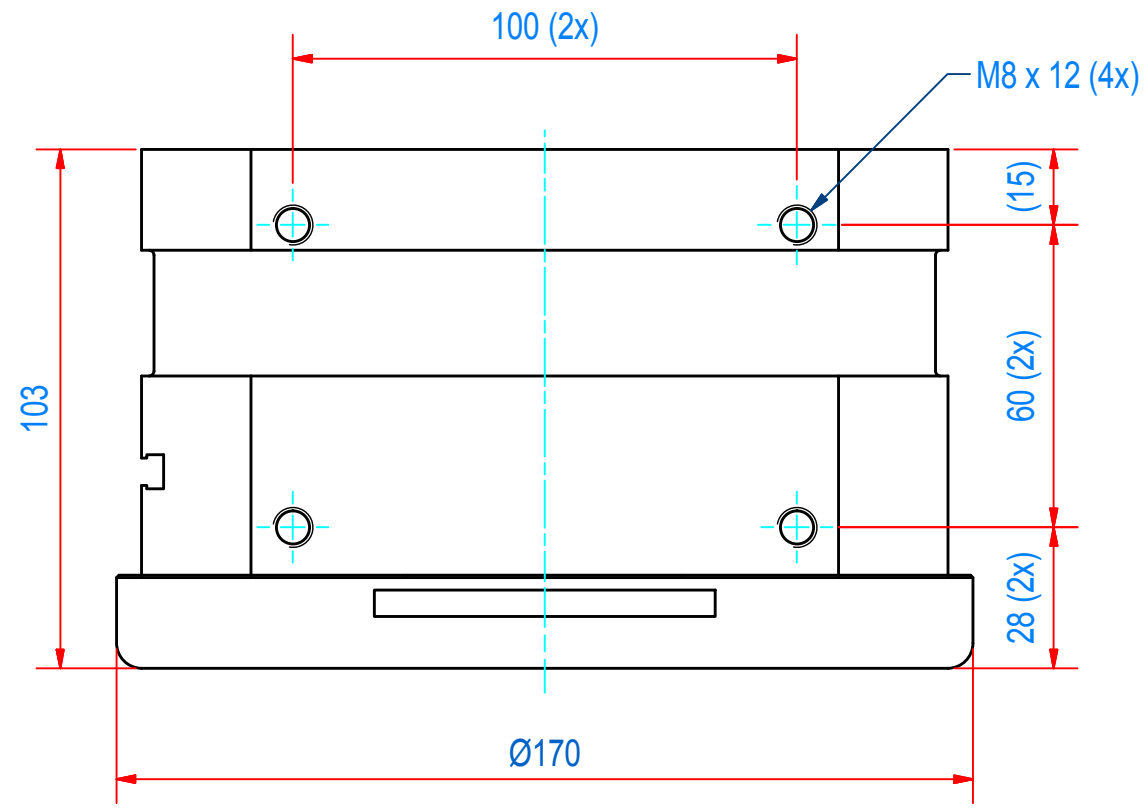
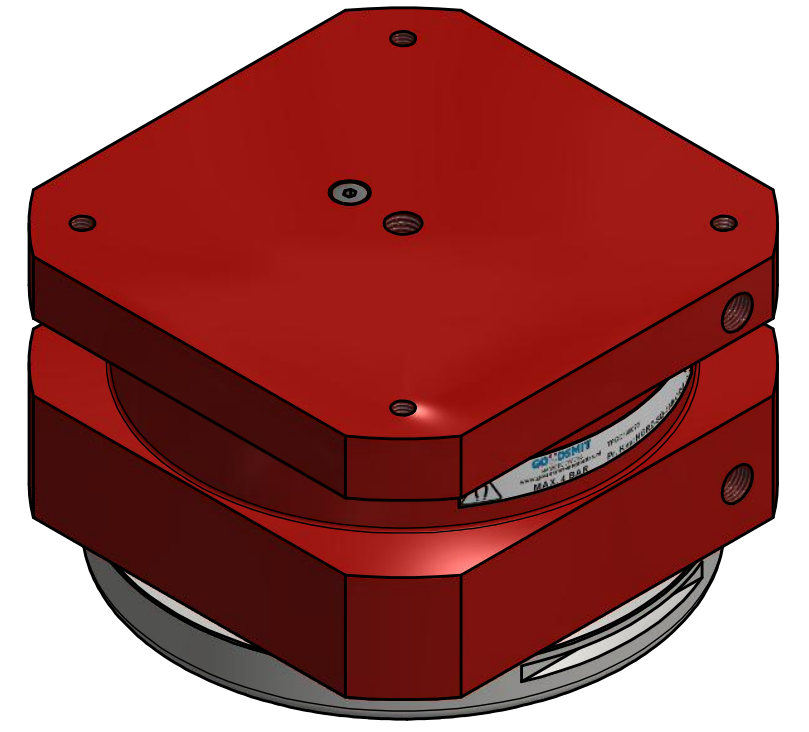

ITEM	QTY	PART NUMBER	DESCRIPTION	Dimensions
2	1	E0038029	STICKER TPGC160078	
1	1	E0034158	MOUNTING ASSY TPGC160	
RAW MAT.	1			
Sheet:	A2	Extra info:	MAGNETIC GRIPPER	General tolerance:
Drawn:	PB	Weight (kg):	5,7	ISO 2768- mK
Date:	8-4-2013			Drawn according:
Spare part:	False			ISO268; ISO1101; ISO2553
Quick search:	TPGC160	<small>© All rights reserved. Reproduction is not permitted without written permission of GOUDSMIT Magnetic Systems BV</small>		Status:
Description:	HGR-SQ-160-FL-F-G-S	File number:	TPGC160078	Standard
		Part number:	TPGC160078	Customer reference number:
				Rev: B
				Rev: B

REV	DATE	BY	DESCRIPTION
-	18-6-2013	BS	NEW VAULT, NOTHING CHANGED, IS EQUAL TO OLD REVISION A
A	16-11-2015	AvD	SCREW CAP AND PISTON CHANGED

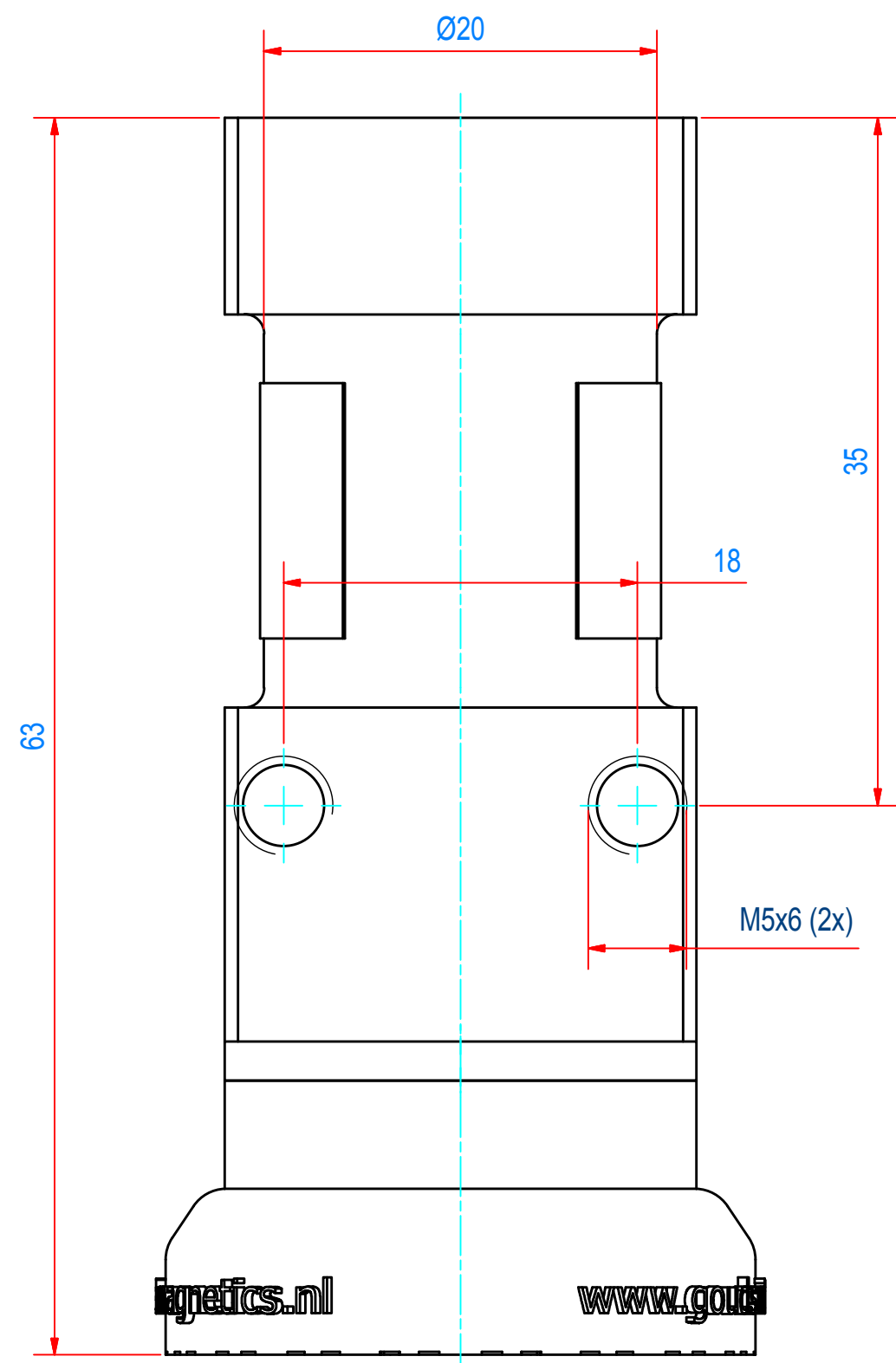
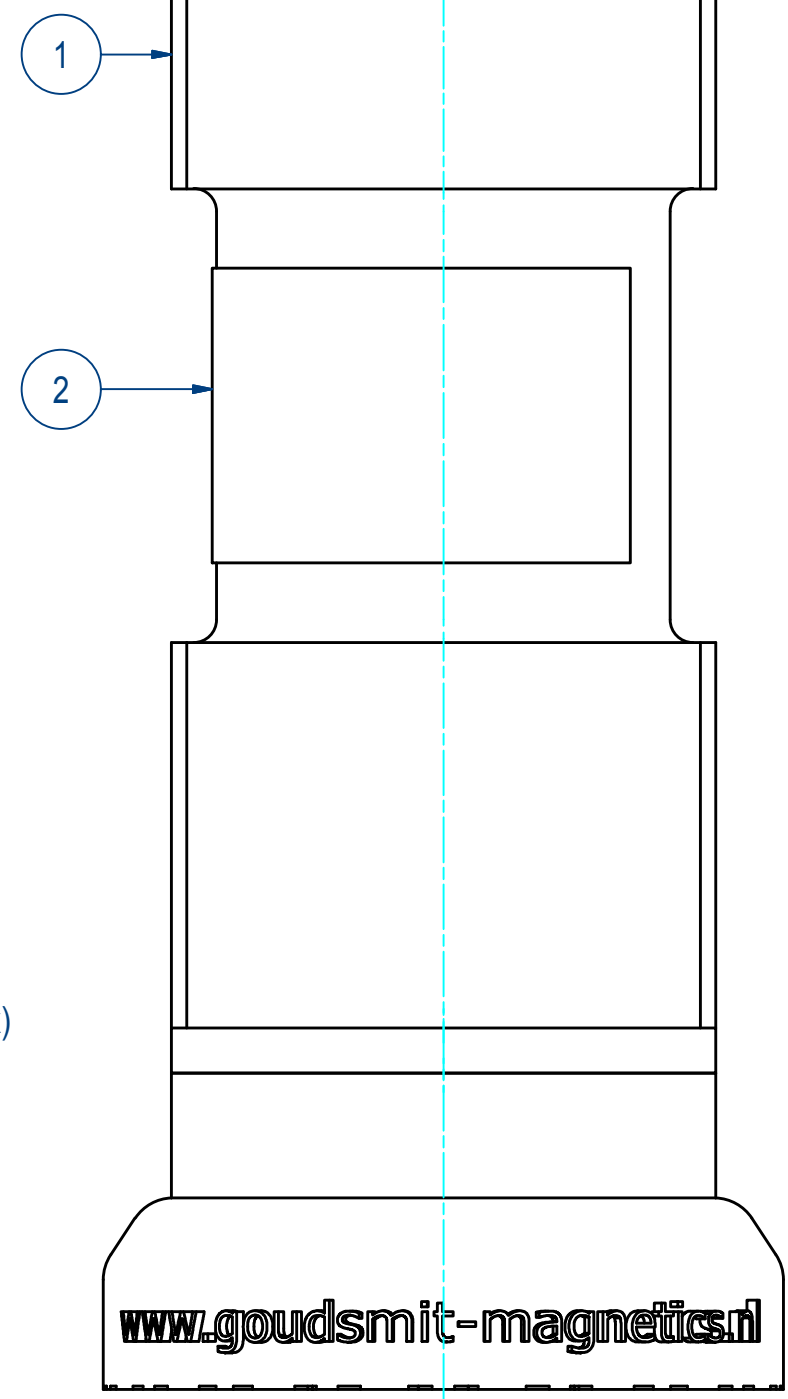
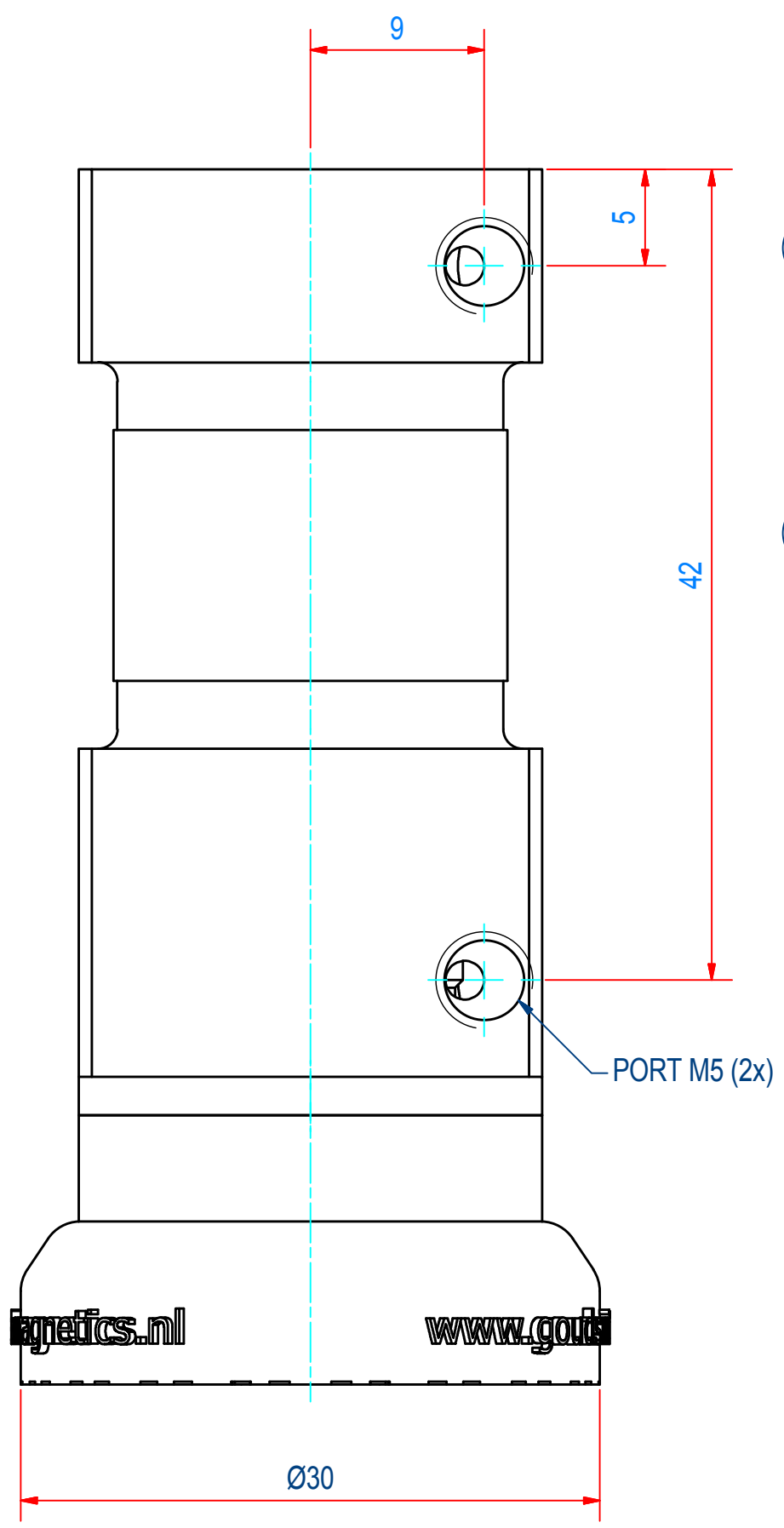
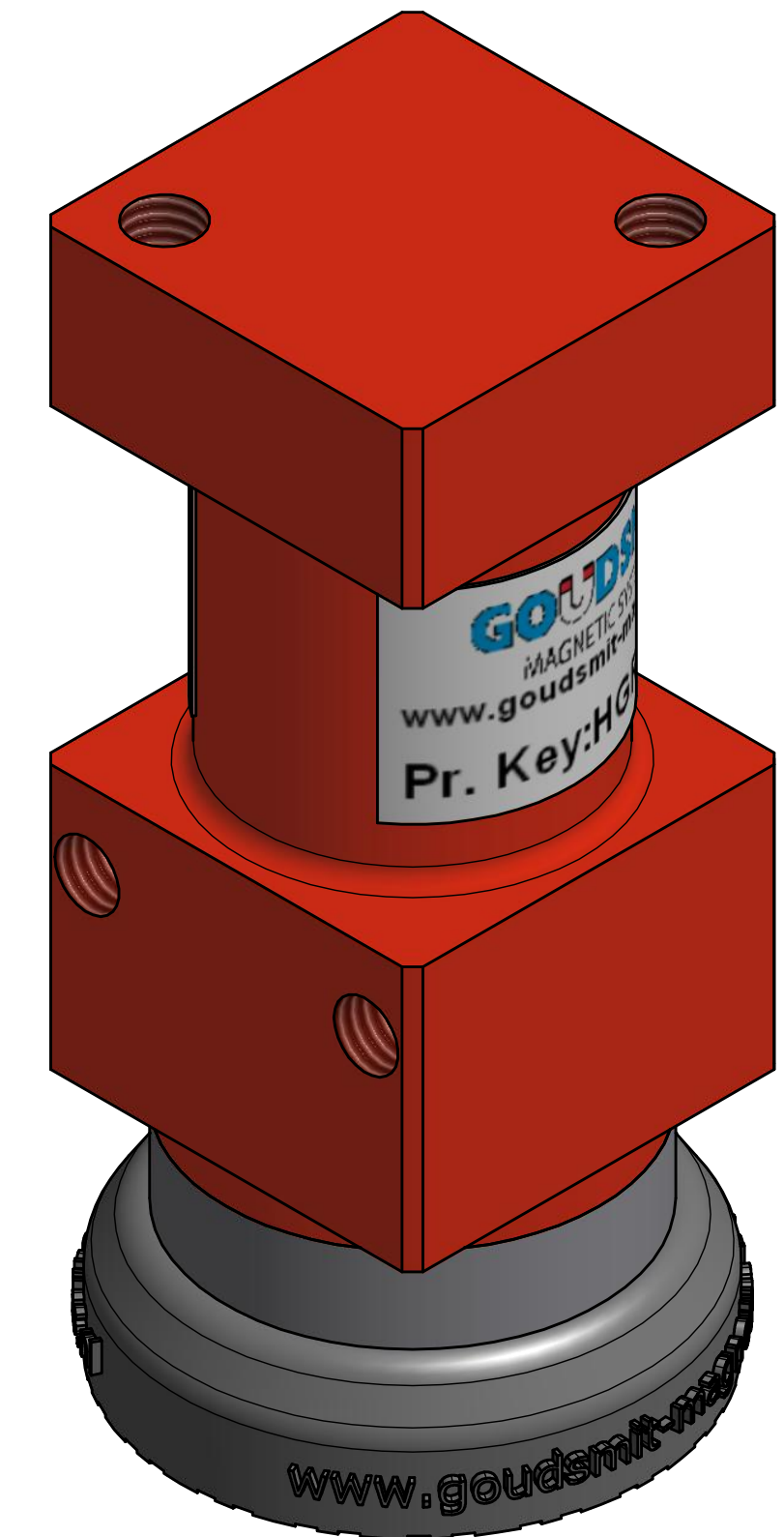
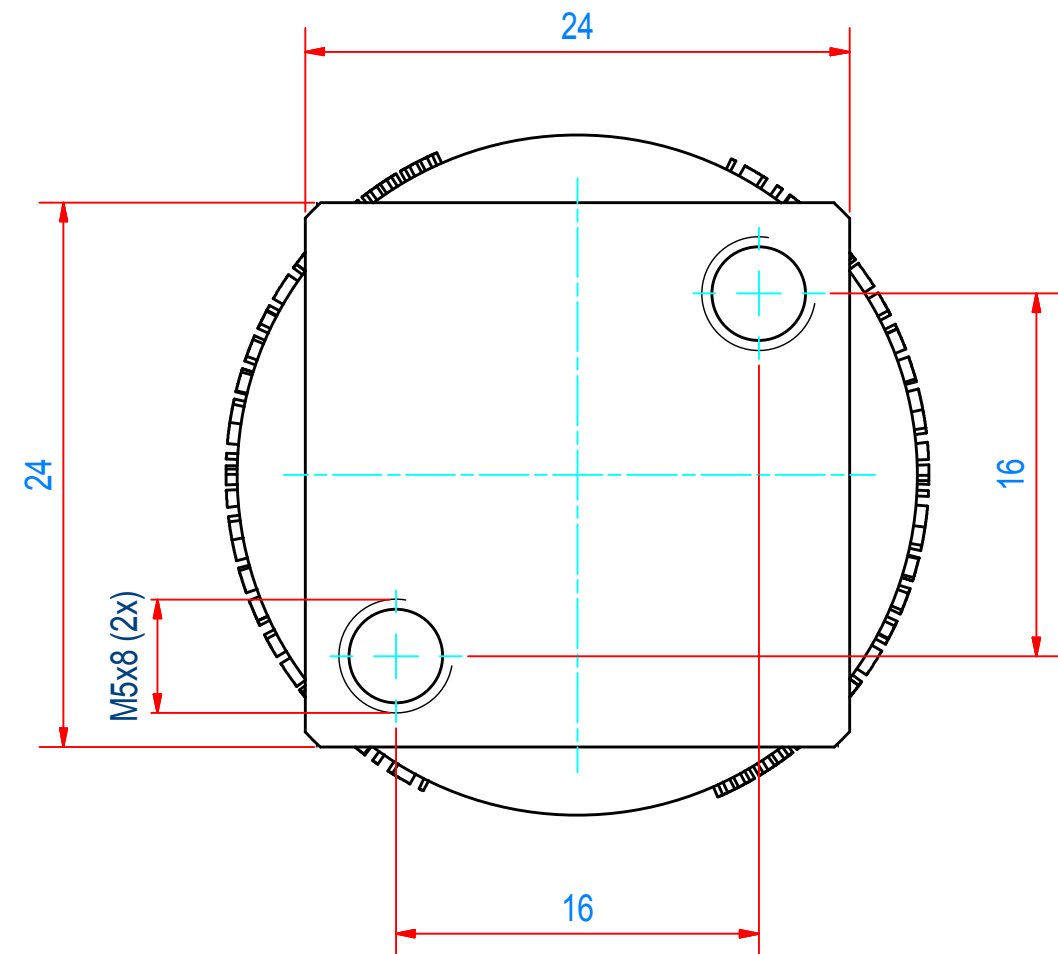

ITEM	QTY	PART NUMBER	DESCRIPTION	Dimensions
2	1	E0037935	STICKER TPGC024088	
1	1	A190252	MOUNTING ASSY TPGC024088	
RAW MAT.	1			
QTY		MAT. NUMBER	MAT. DESCRIPTION	LENGTH (mm) WIDTH (mm)
Sheet: A2		Extra info:		General tolerance: ISO 2768- mK
Drawn: BS	Weight (kg): 0,1	Date: 18-6-2013		Drawn according: ISO268; ISO1101; ISO2553
Spare part: False		Quick search: TPGC024		Status: Standard
Description: HGR-SQ-024-FP-R-M-F		File number: TPGC024088		Customer reference number:
		Part number: TPGC024088		Rev: A



© All rights reserved. Reproduction is not permitted without written permission of GOUDSMIT Magnetic Systems BV

REV	DATE	BY	DESCRIPTION
-	22-10-2013	PB	NEW VAULT, NEW REVISION. NOTHING CHANGED. OLD REV WAS A
A	24-11-2017	PV	ITEM 3 (PLUG) ADDED

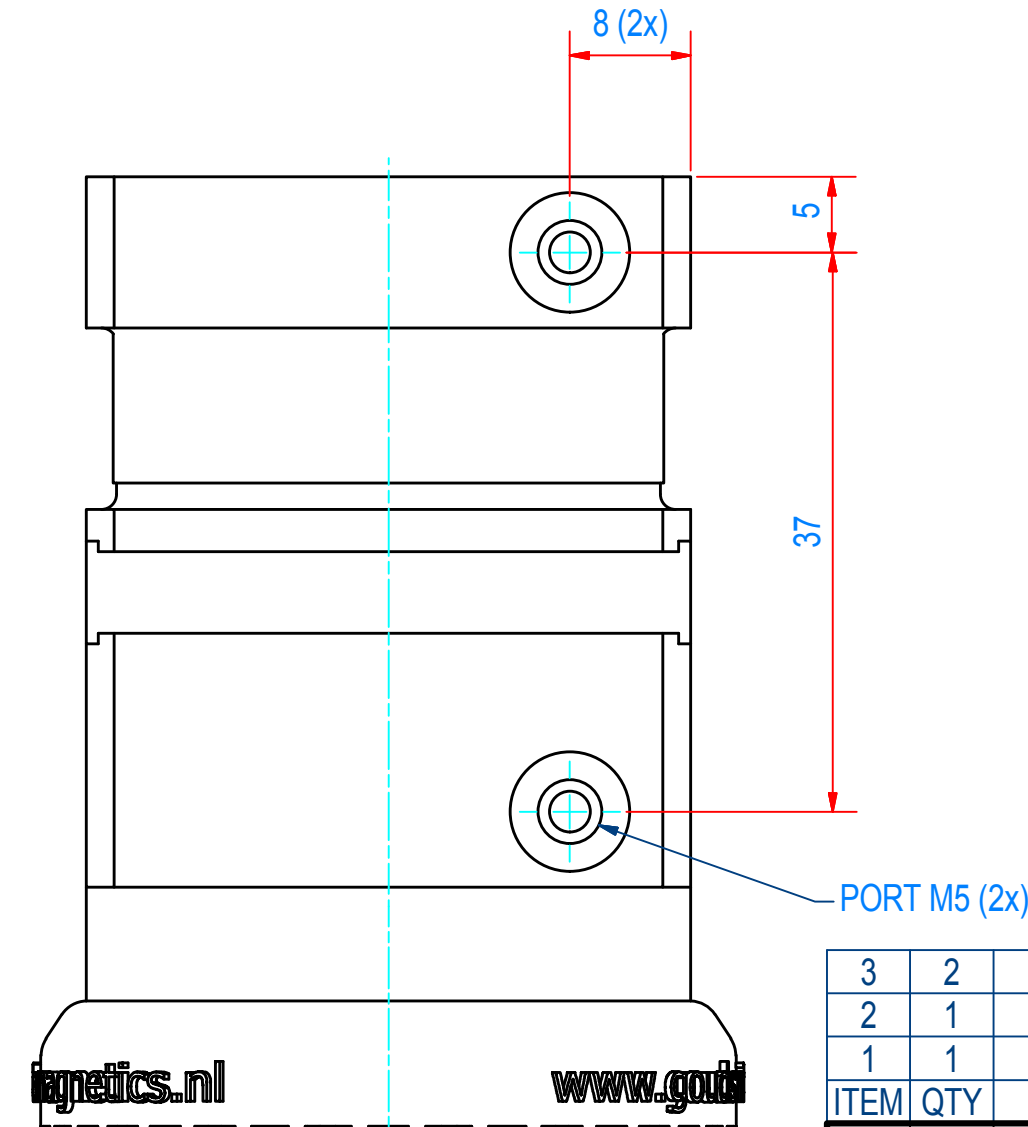
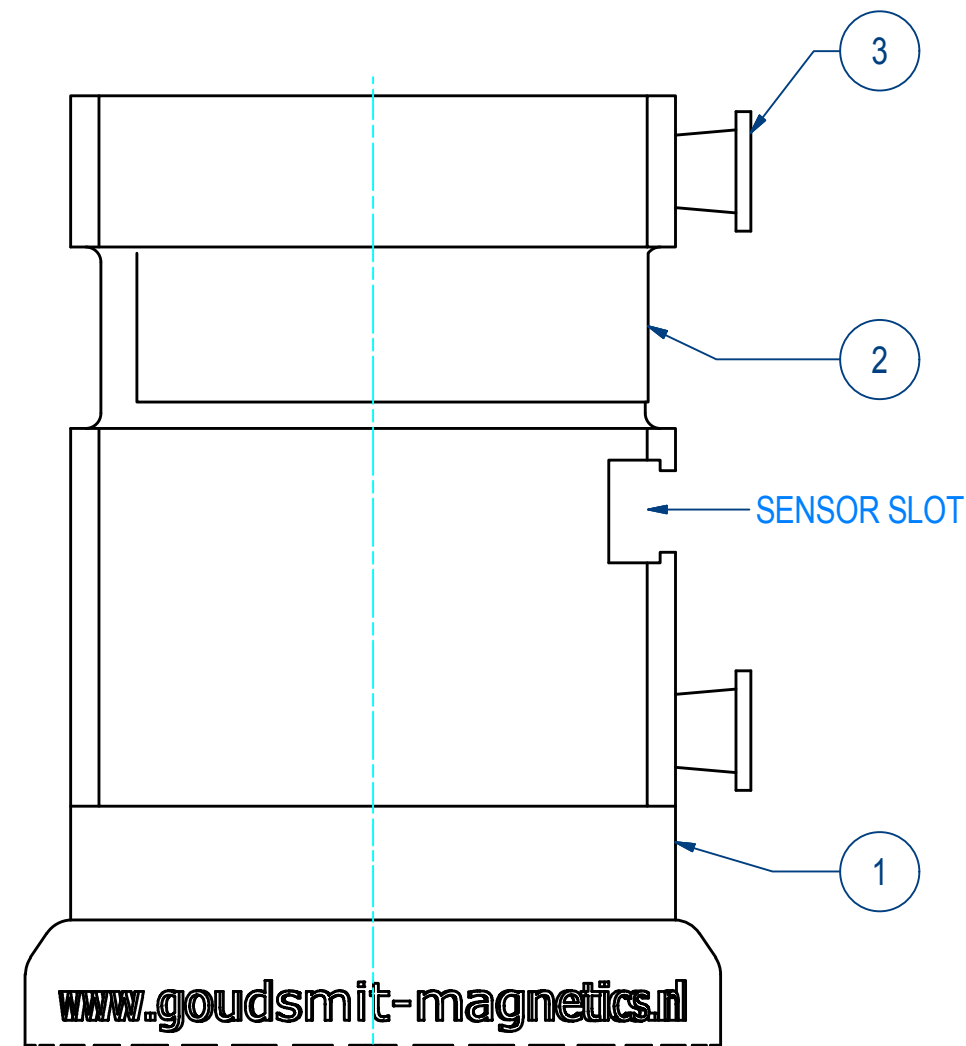
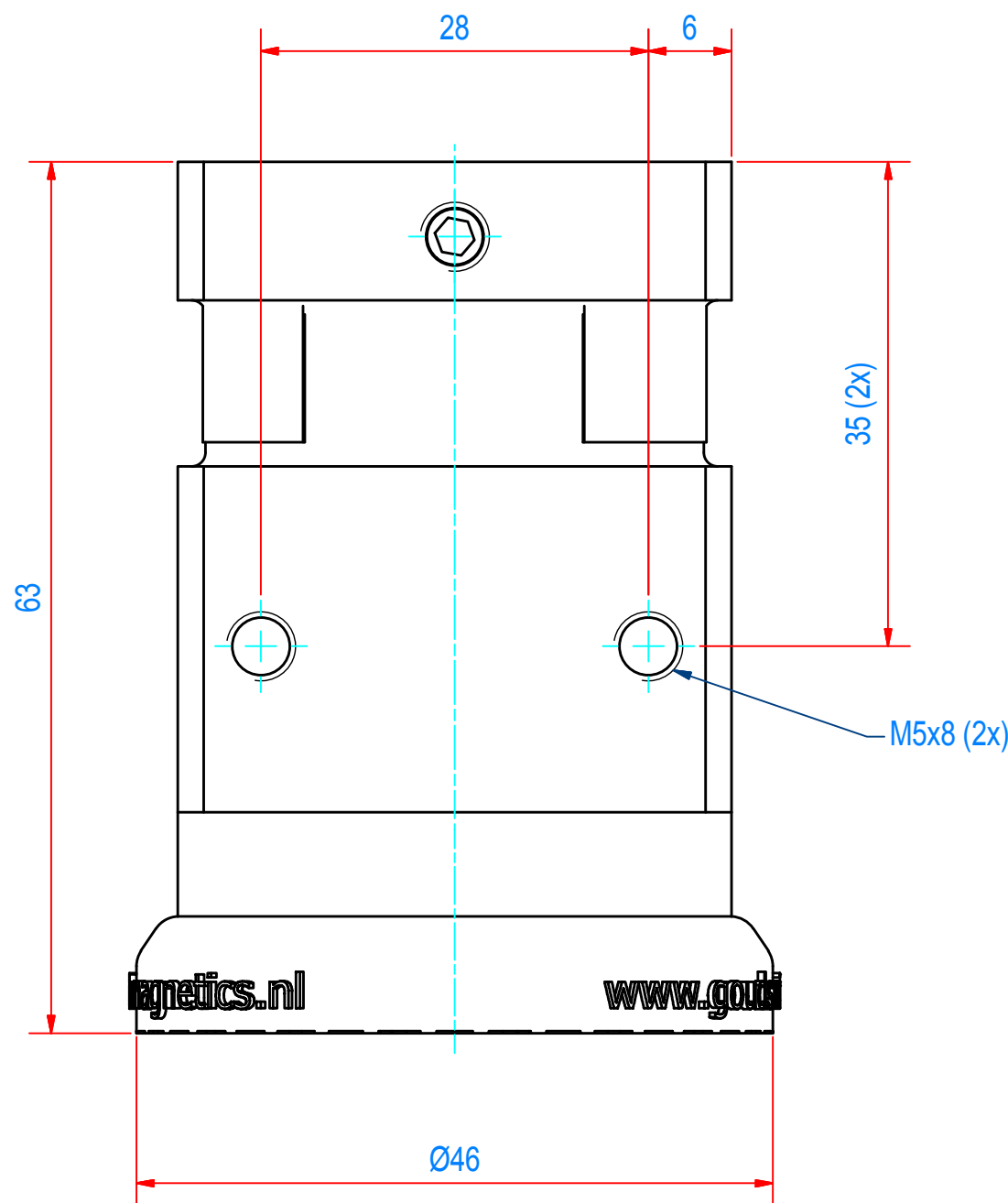
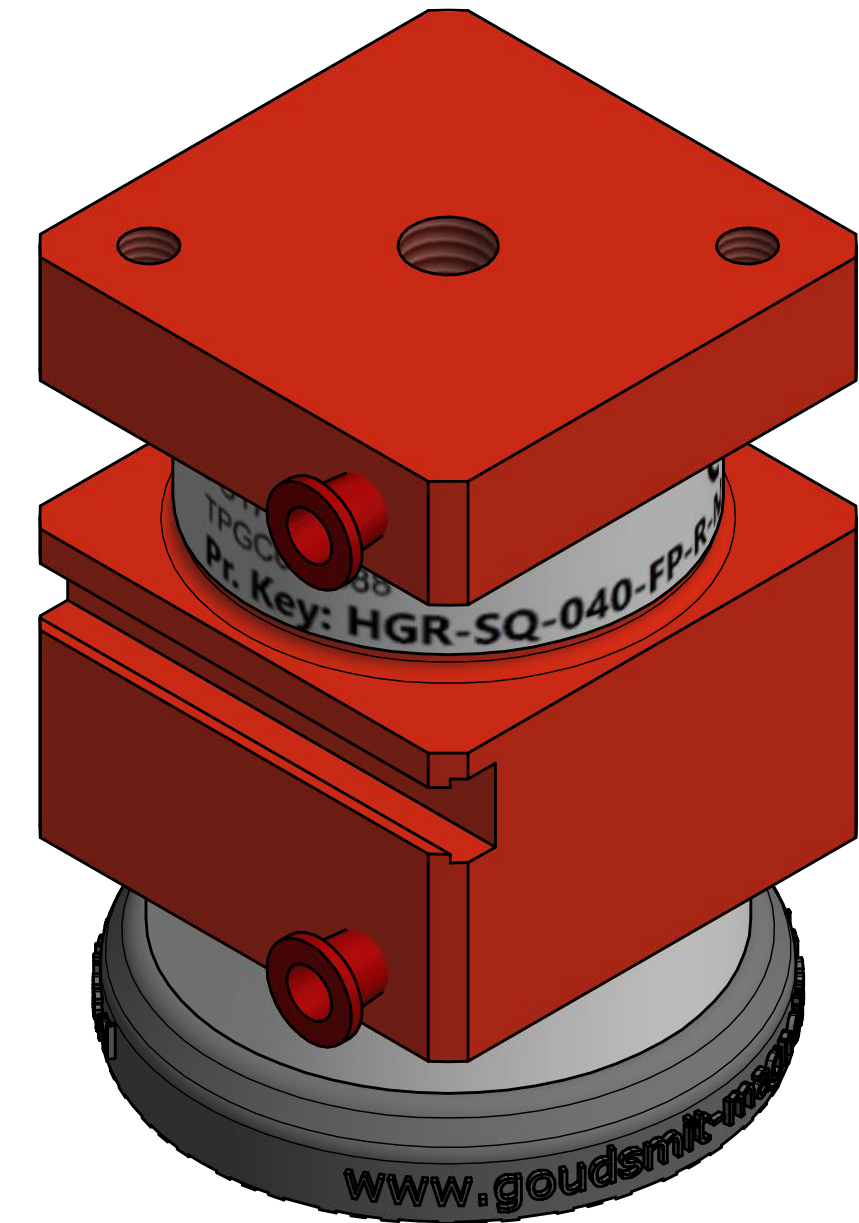
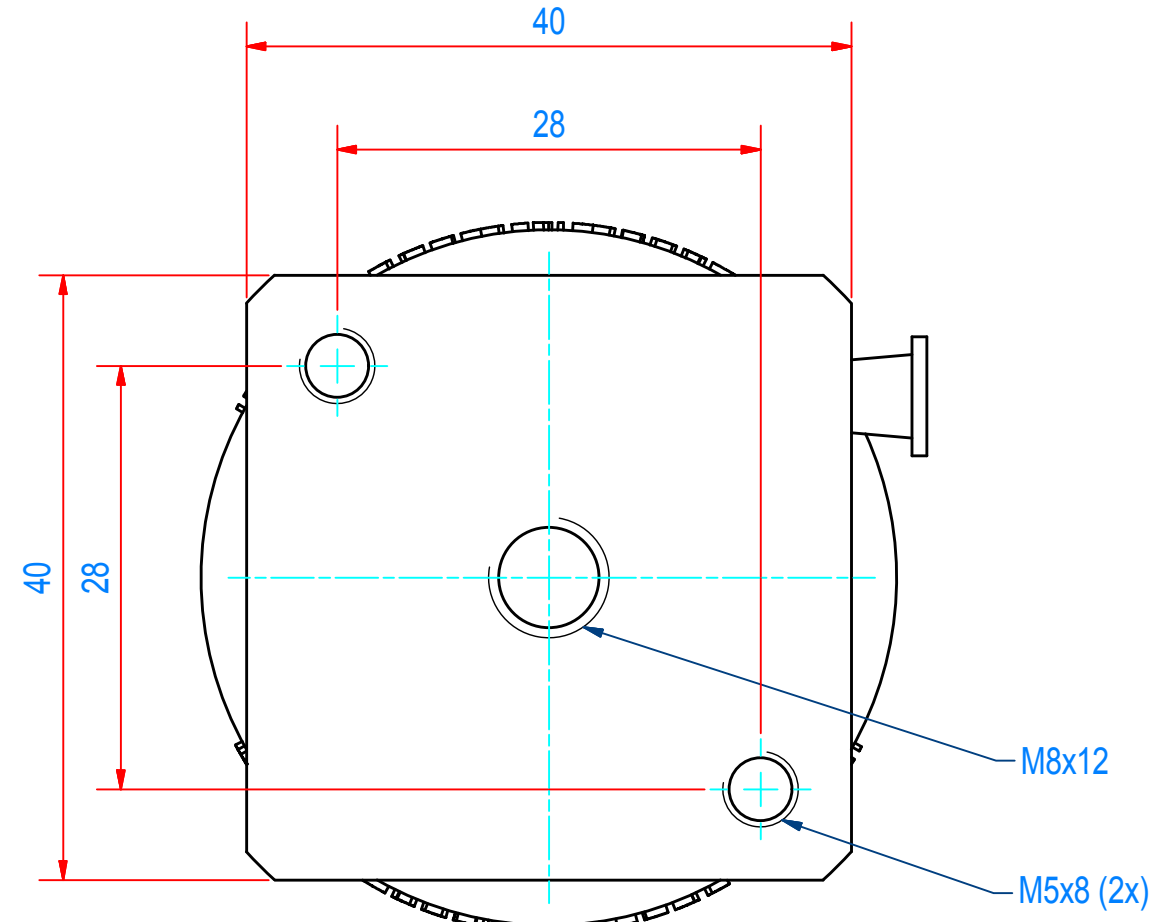

ITEM	QTY	PART NUMBER	DESCRIPTION	Dimensions
3	2	1009.30013	PLUG LDPE M5	
2	1	E0038046	STICKER TPGC040088	
1	1	A190072	MOUNTING ASSY TPGC040088	

RAW MAT.	QTY	MAT. NUMBER	MAT. DESCRIPTION	LENGTH (mm)	WIDTH (mm)
⊕	1				

Sheet: A2	Extra info:	General tolerance: ISO 2768 - mK
Drawn: BS	Weight (kg): 0,2	Drawn according: ISO268; ISO1101; ISO2553
Date: 22-10-2013		Status: Standard
Spare part: False		Customer reference number:
Quick search: TPGC040	GOUDSMIT MAGNETIC SYSTEMS <small>© All rights reserved. Reproduction is not permitted without written permission of GOUDSMIT Magnetic Systems BV</small>	File number: E0086390
Description: HGR-SQ-040-FP-R-M-S		Part number: TPGC040088

REV	DATE	BY	DESCRIPTION
-	18-12-2013	BS	NEW VAULT, NOTHING CHANGED, IS EQUAL TO OLD REVISION A

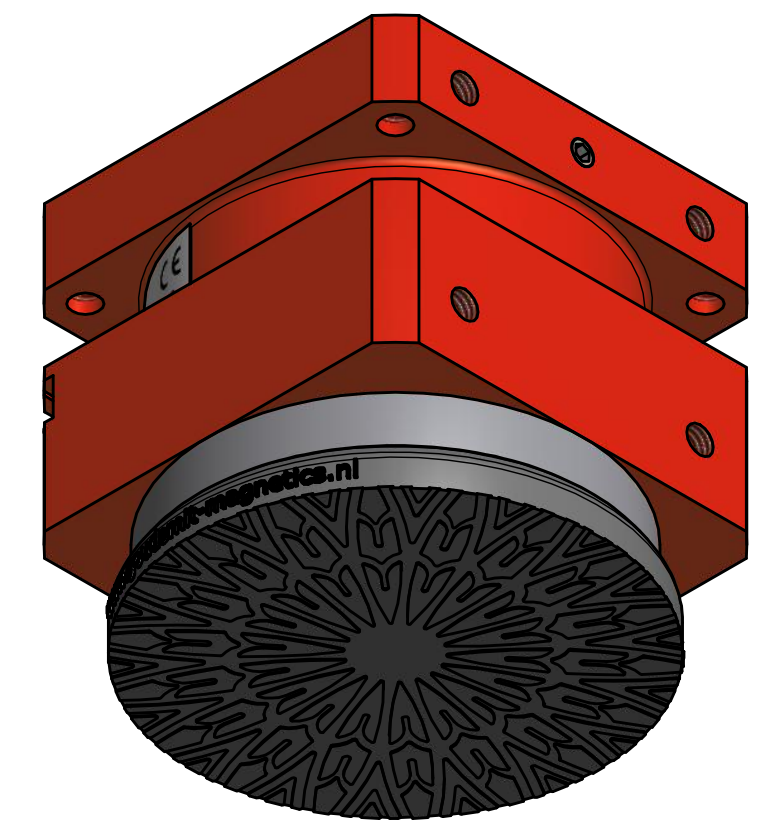
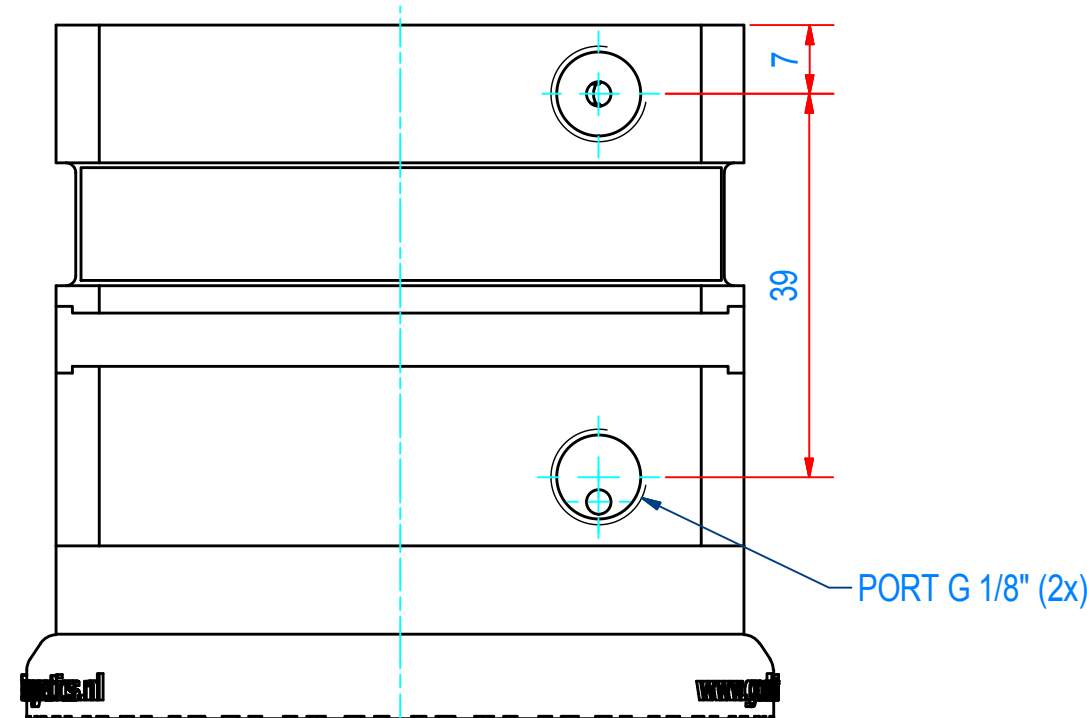
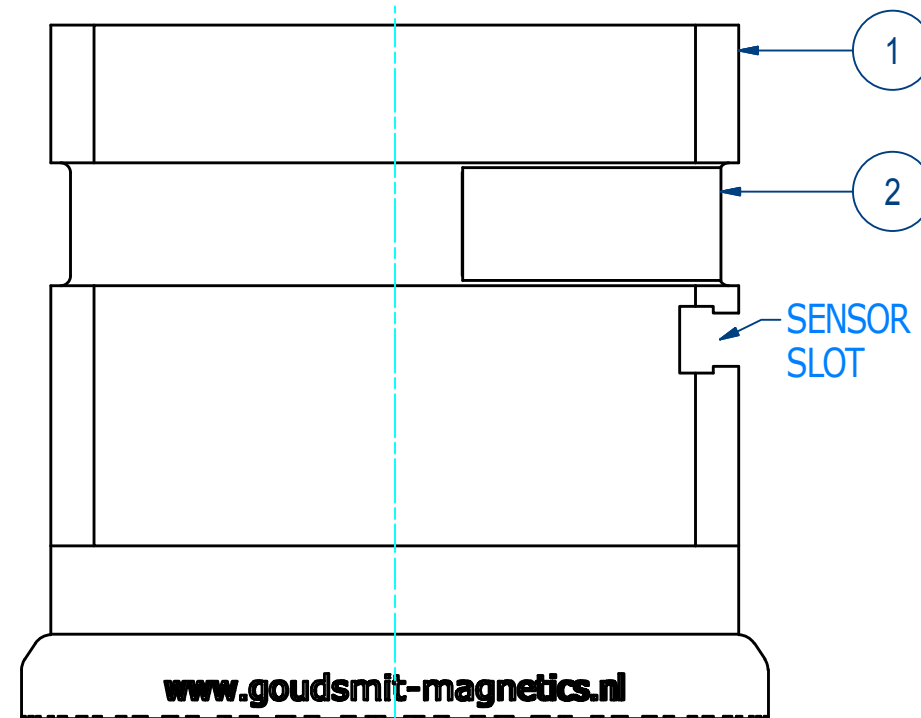
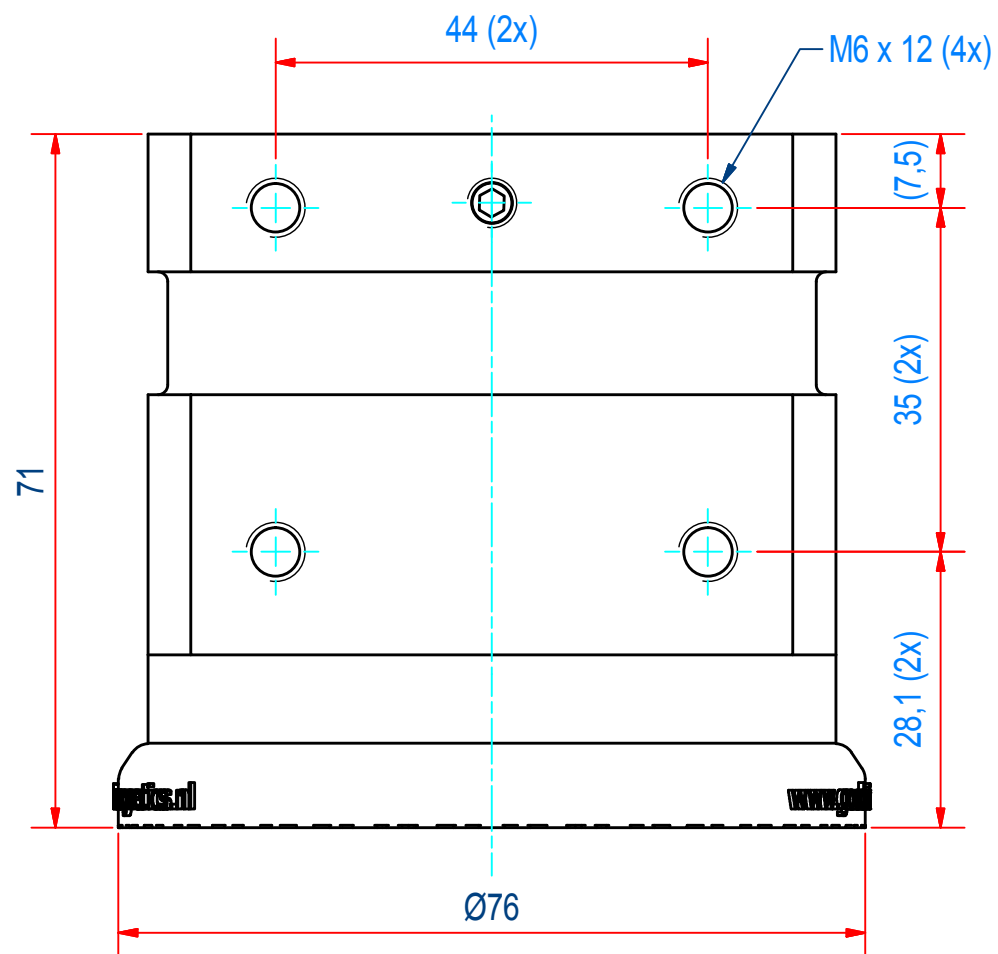
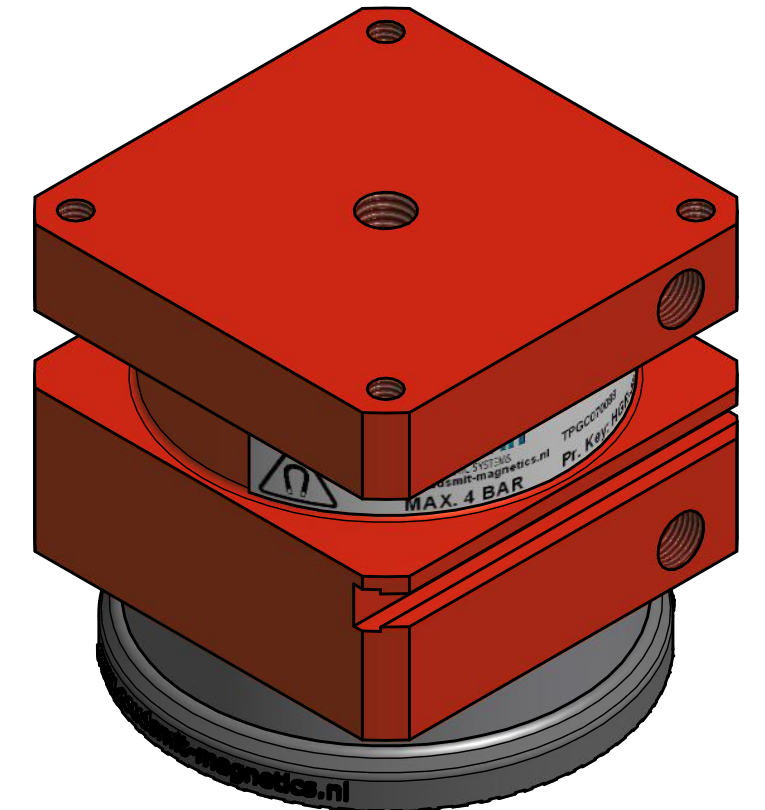
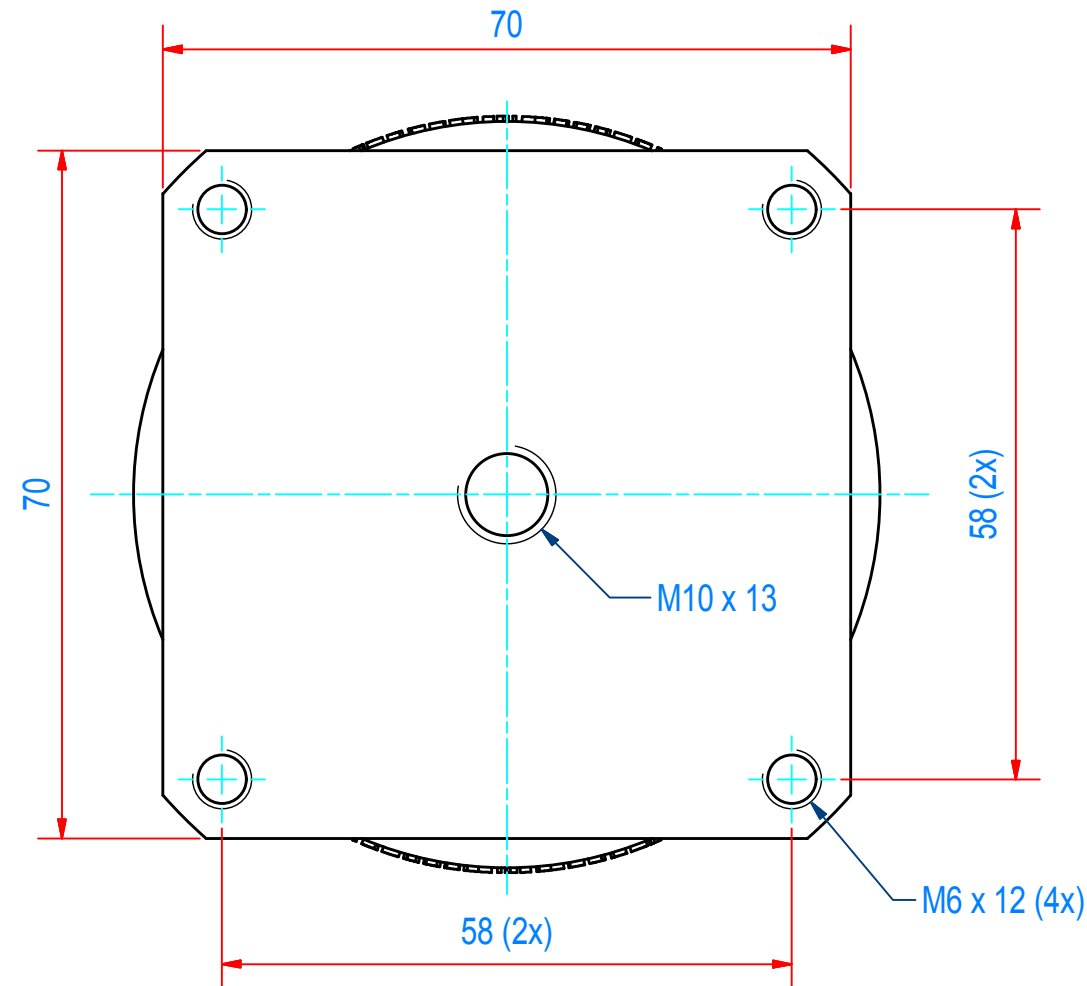

ITEM	QTY	PART NUMBER	DESCRIPTION	Dimensions
2	1	E0038049	STICKER TPGC070088	
1	1	A190243	MOUNTING ASSY TPGC070088	
RAW MAT.	1			
	QTY	MAT. NUMBER	MAT. DESCRIPTION	LENGTH (mm) WIDTH (mm)
Sheet: A2		Extra info:		General tolerance: ISO 2768 - mK
Drawn: BS		Weight (kg): 0,8		Drawn according: ISO268; ISO1101; ISO2553
Date: 17-12-2013		Goudsmits MAGNETIC SYSTEMS		Status: Standard
Spare part: False		© All rights reserved. Reproduction is not permitted without written permission of GOUDSMIT Magnetic Systems BV		Customer reference number:
Quick search: TPGC070		Description: HGR-SQ-070-FP-R-G-S		File number: TPGC070088 Rev: -
				Part number: TPGC070088 Rev: -

REV	DATE	BY	DESCRIPTION
-	18-12-2013	BS	NEW VAULT, NOTHING CHANGED, IS EQUAL TO OLD REVISION A

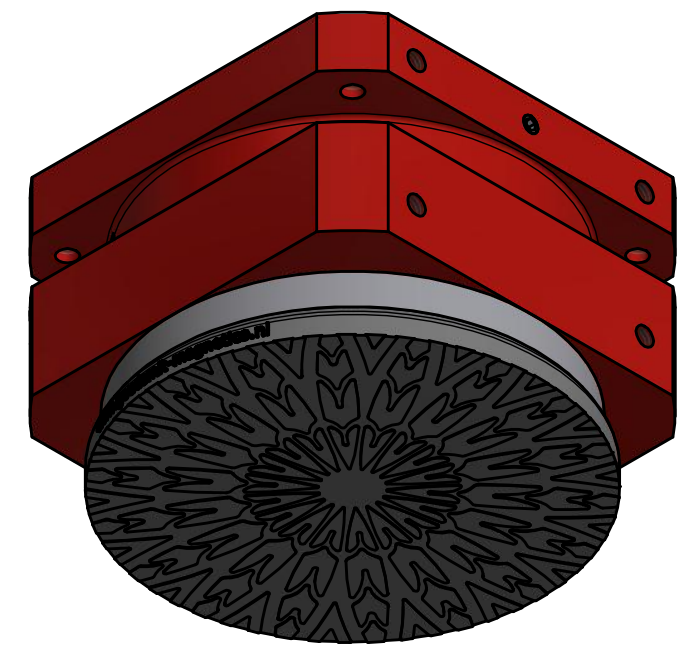
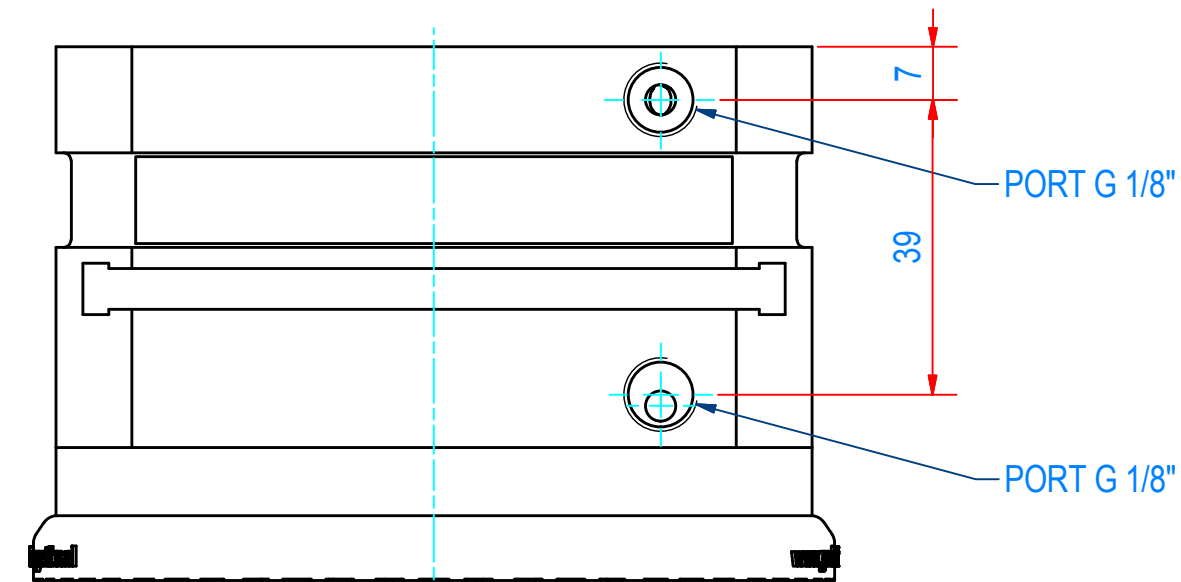
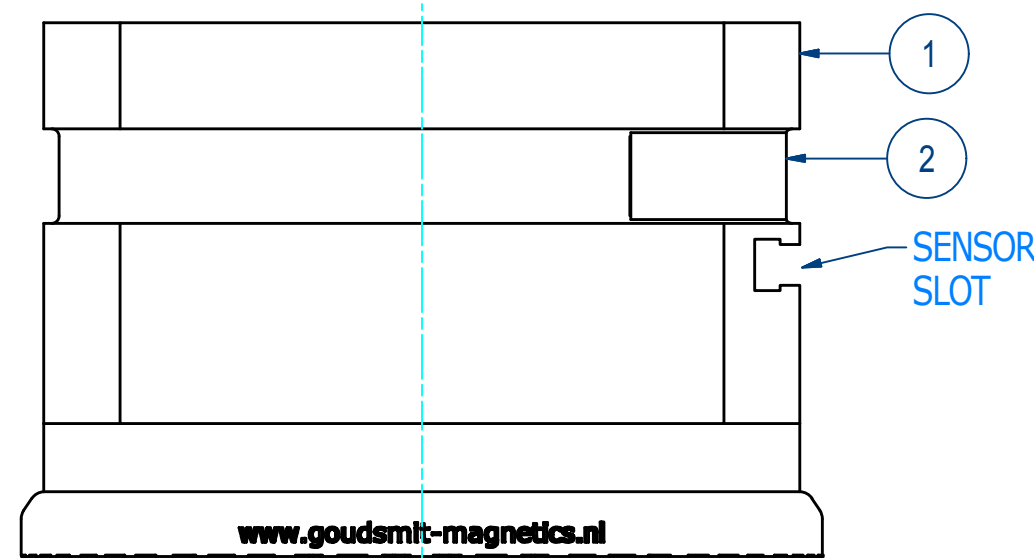
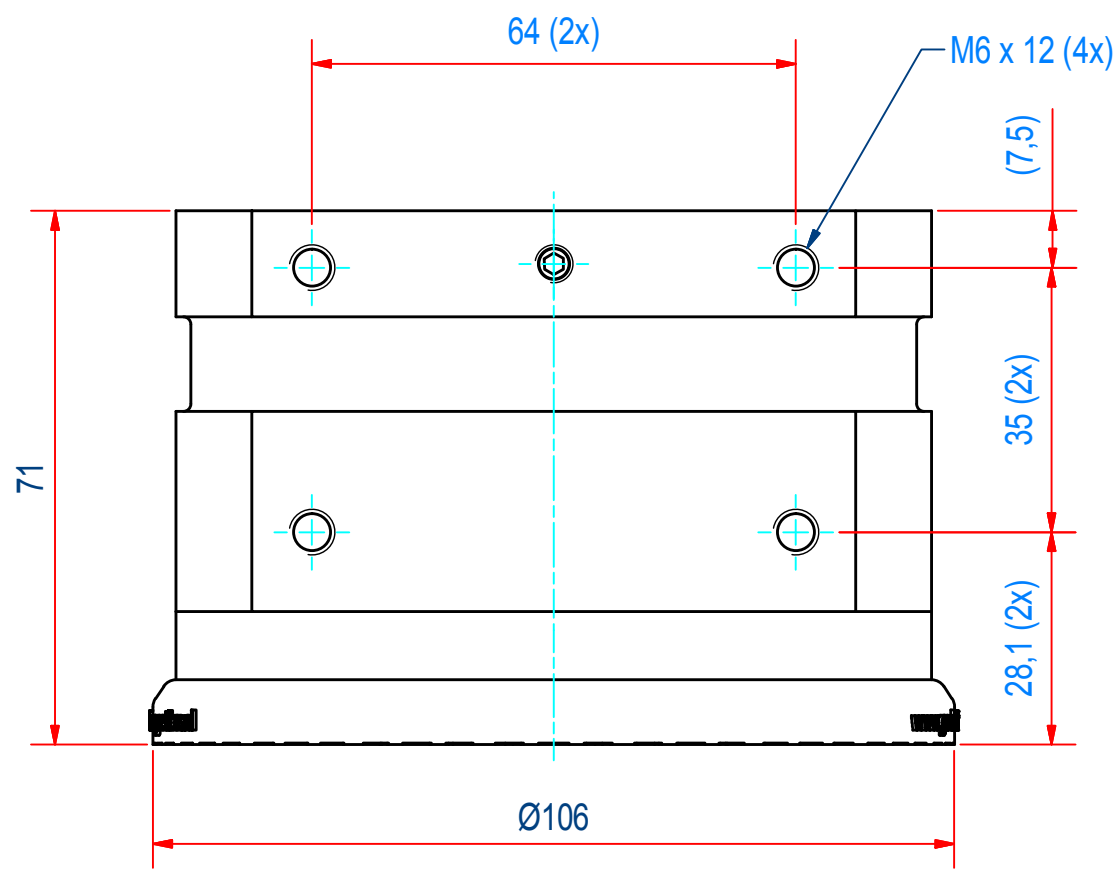
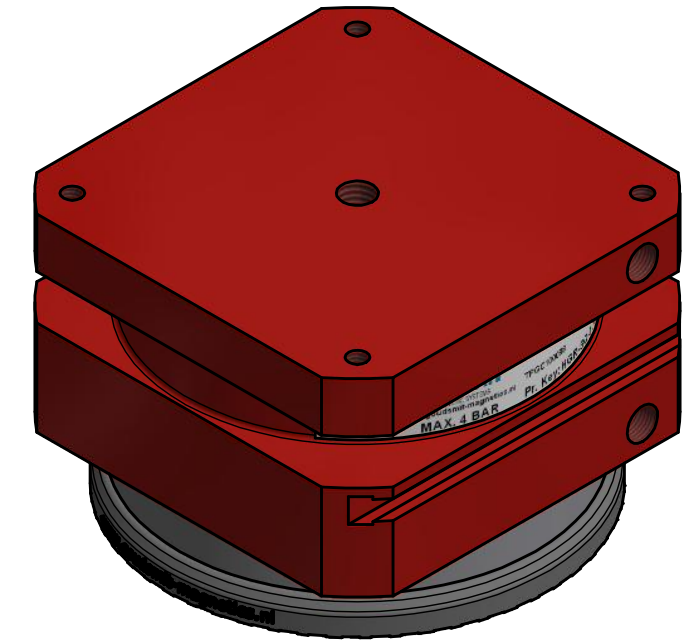
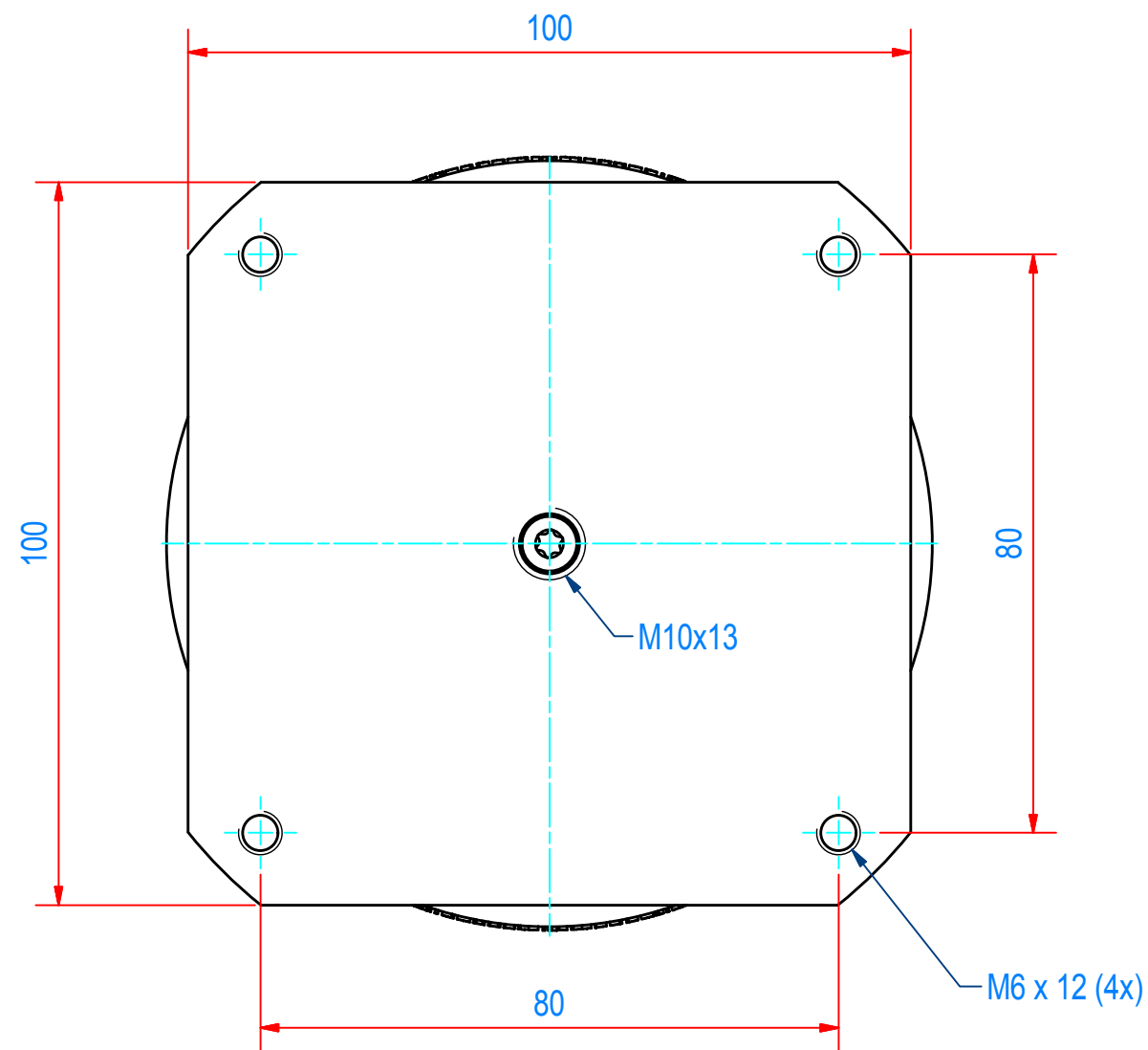

ITEM	QTY	PART NUMBER	DESCRIPTION	Dimensions
2	1	E0038051	STICKER TPGC100088	
1	1	A190306	MOUNTING ASSY TPGC100088	
RAW MAT.	1			
QTY		MAT. NUMBER	MAT. DESCRIPTION	LENGTH (mm) WIDTH (mm)
Sheet:	A2	Extra info:	General tolerance:	ISO 2768- mK
Drawn:	BS	Weight (kg):	1,5	Drawn according:
Date:	17-12-2013			ISO268; ISO1101; ISO2553
Spare part:	False			Status:
Quick search:	TPGC100			Standard
Description:	HGR-SQ-100-FP-R-G-S			Customer reference number:
				File number:
				TPGC100088
				Rev:
				-
				Part number:
				TPGC100088
				Rev:
				-



© All rights reserved. Reproduction is not permitted without written permission of GOUDSMIT Magnetic Systems BV

REV	DATE	BY	DESCRIPTION
-	9-7-2013	BS	NEW VAULT, NOTHING CHANGED, IS EQUAL TO OLD REVISION A
A	3-12-2014	GS	MOUNTING ASSY WAS A190496
B	12-11-2015	AvD	ITEM 1 CHANGED: E0044336 WAS E0025632

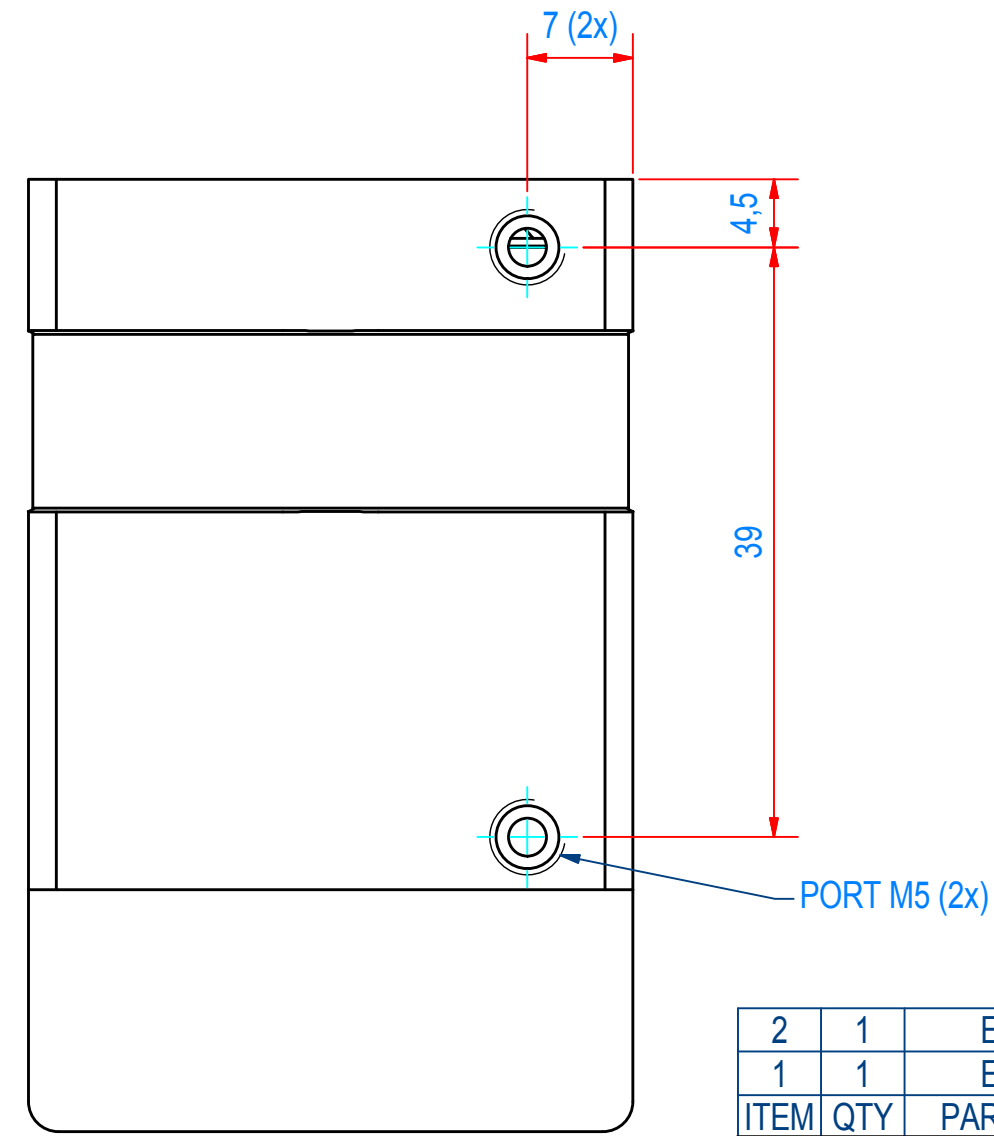
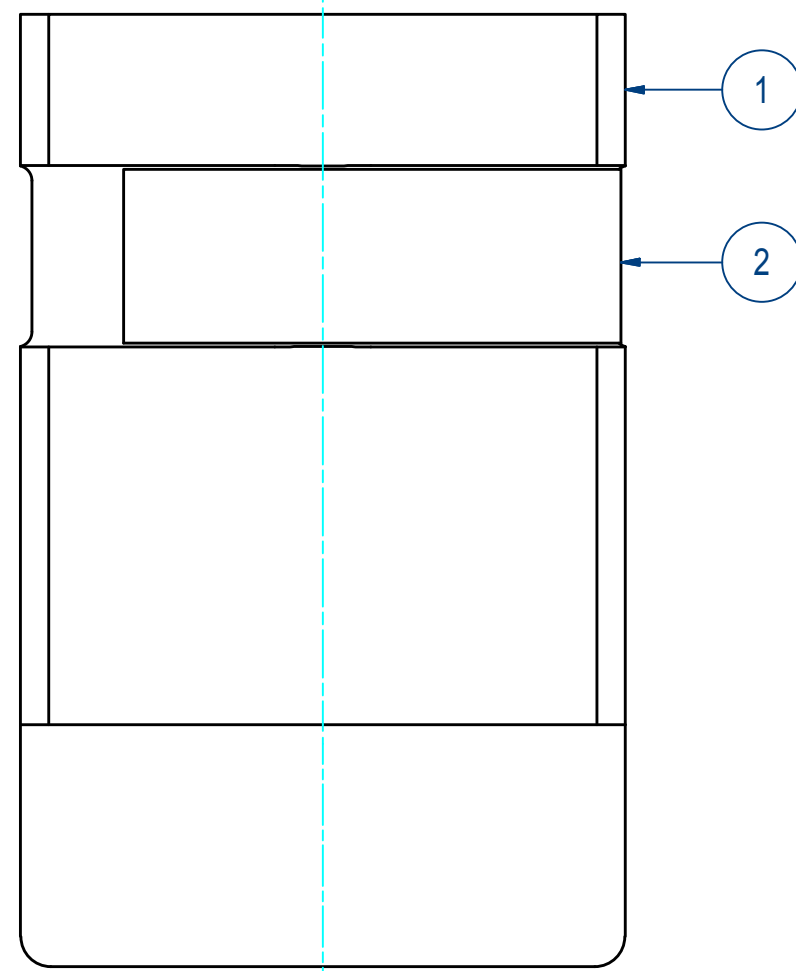
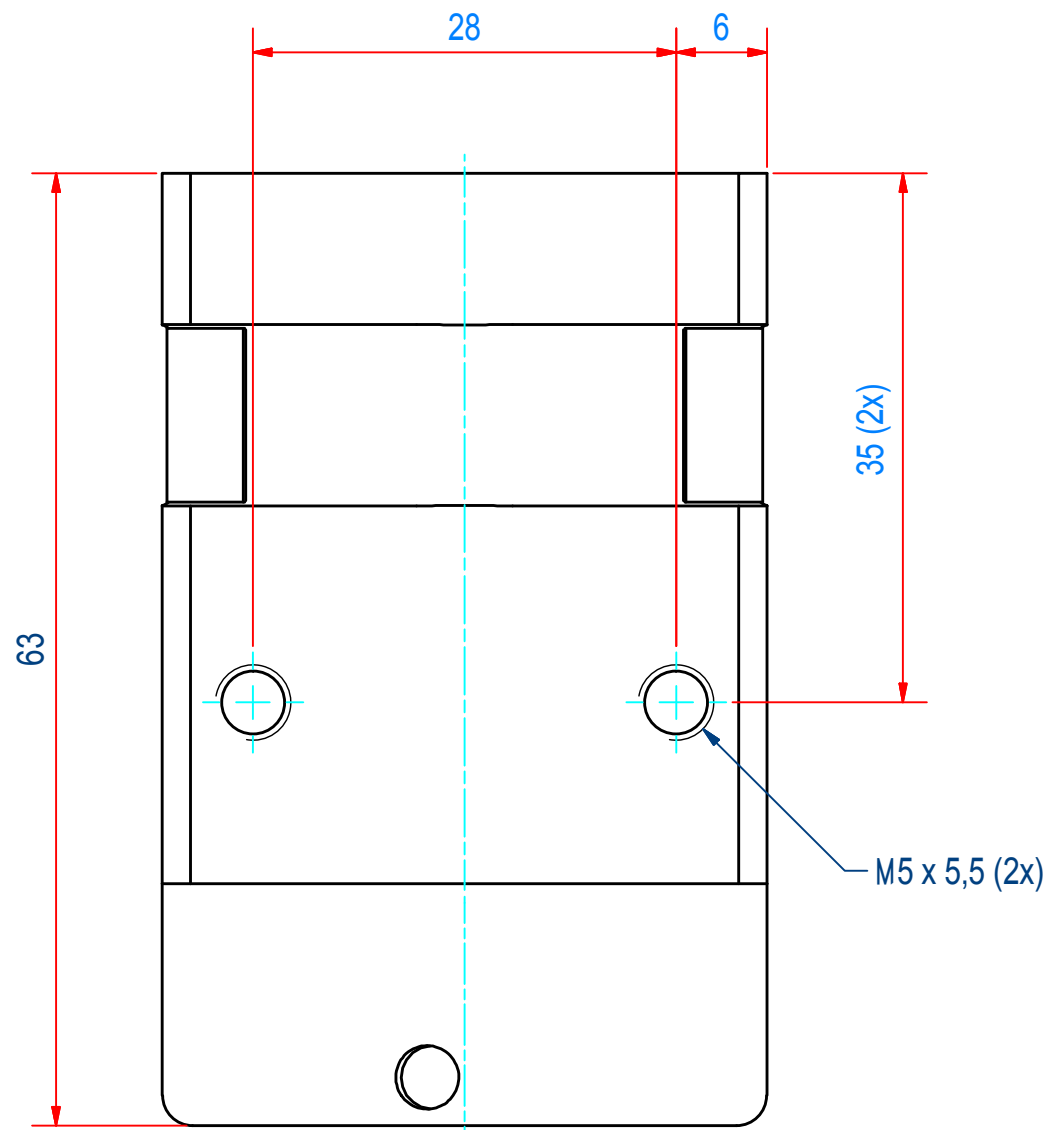
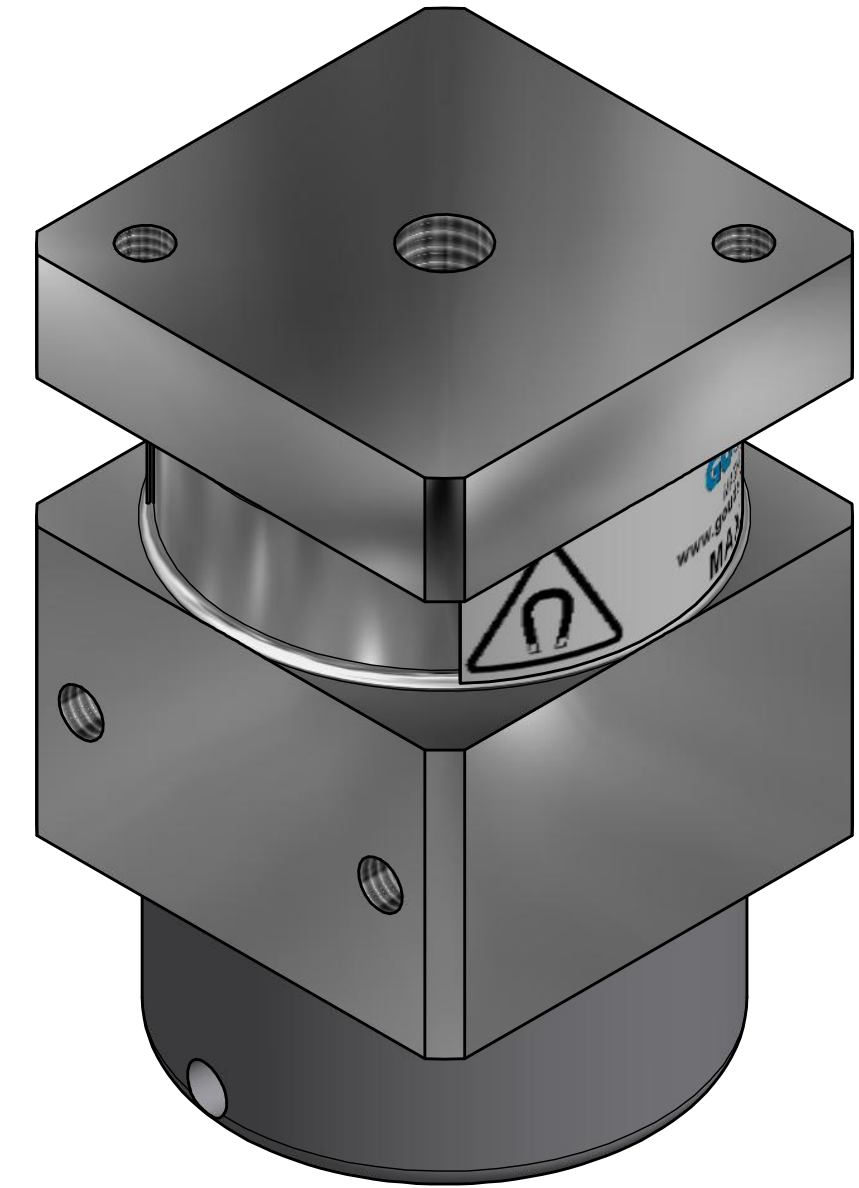
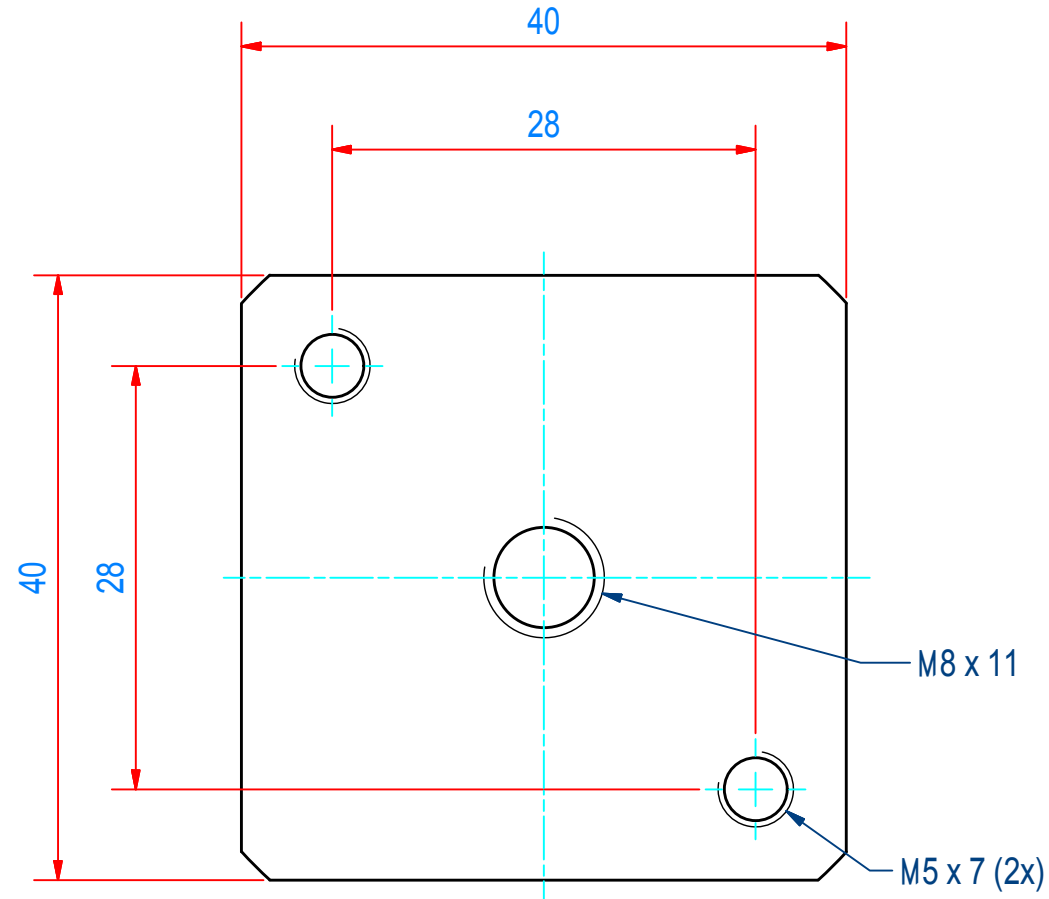

ITEM	QTY	PART NUMBER	DESCRIPTION	Dimensions
2	1	E0038038	STICKER TPGC040378	
1	1	E0044336	MOUNTING ASSY TPGC040378	
RAW MAT.	1			LENGTH (mm) WIDTH (mm)

Sheet: A2	Extra info: AMBIENT TEMP. MAX. 120°C	General tolerance: ISO 2768- mK
Drawn: AvD	Weight (kg): 0,2	Drawn according: ISO268; ISO1101; ISO2553
Date: 12-11-2015		Status: Standard
Spare part: False		Customer reference number:
Quick search: TPGC040	© All rights reserved. Reproduction is not permitted without written permission of GOUDSMIT Magnetic Systems BV	File number: TPGC040378
Description: HGR-SQ-040-FL-RH-M-F		Part number: TPGC040378

NEXT STEP
automation

(주)넥스텝

Tel. 053-604-3040 Fax. 053-604-3042
Web.nstep.co.kr Mob.010-4488-3040

REV	DATE	BY	DESCRIPTION
-	9-7-2013	BS	NEW VAULT, NOTHING CHANGED, IS EQUAL TO OLD REVISION A
A	2-12-2013	PB	E0010955 WAS A190494
B	16-10-2014	PB	E0016901 WAS E0010955

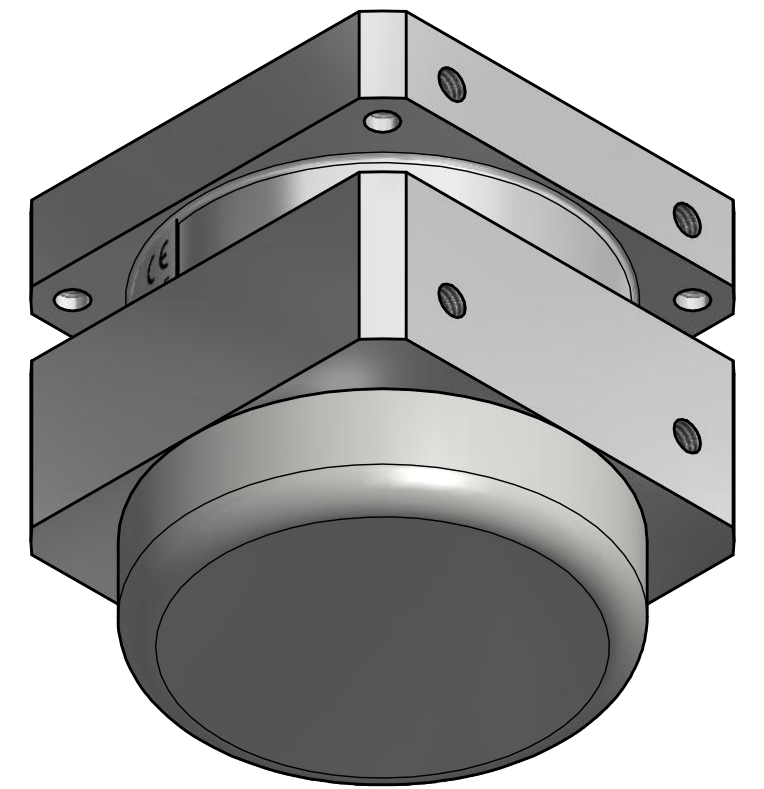
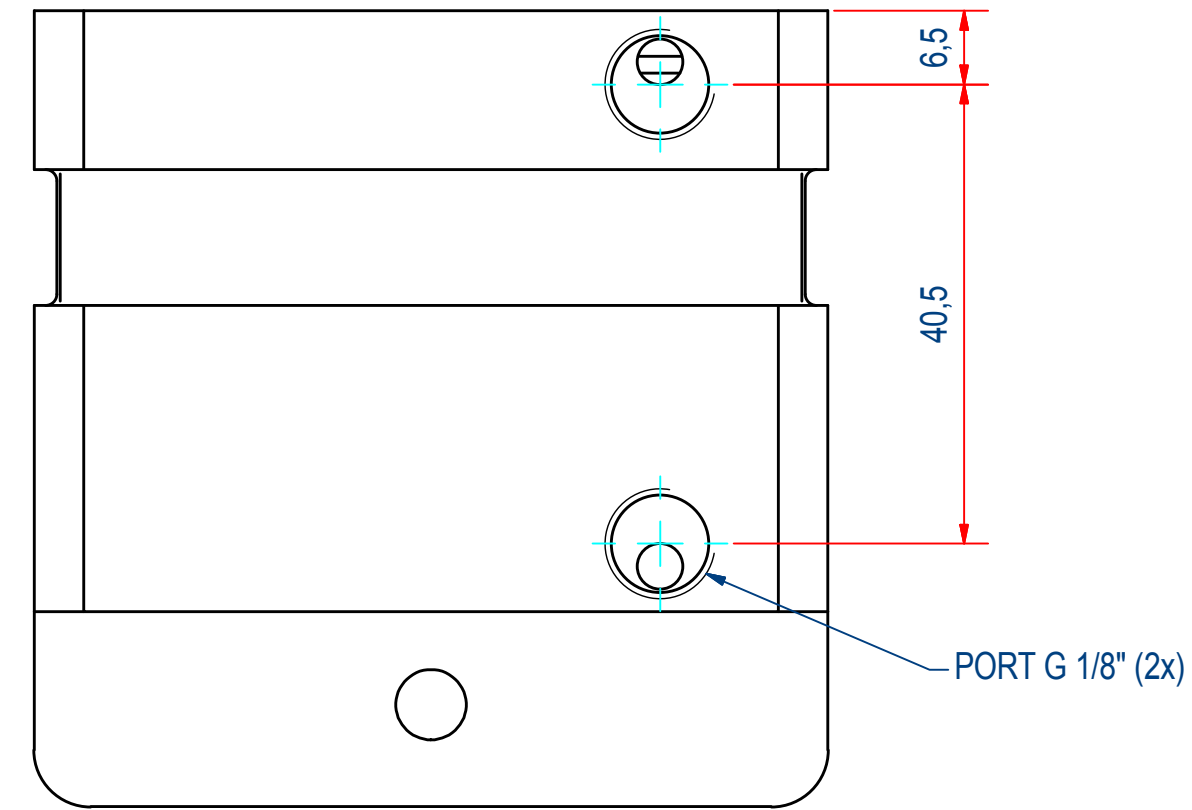
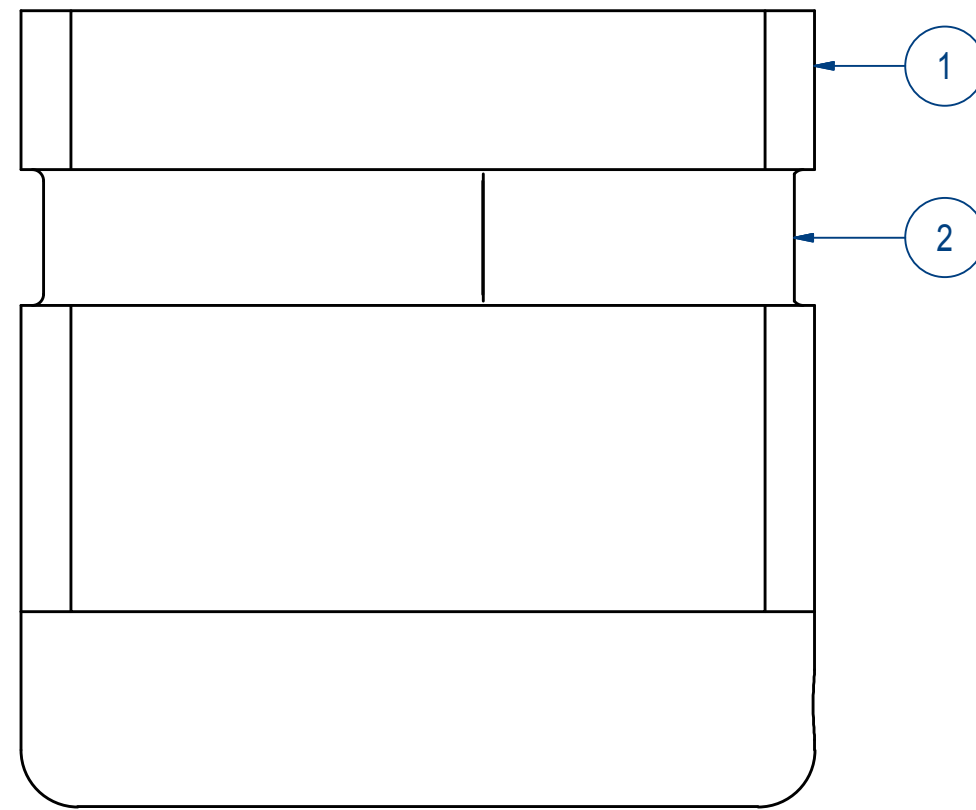
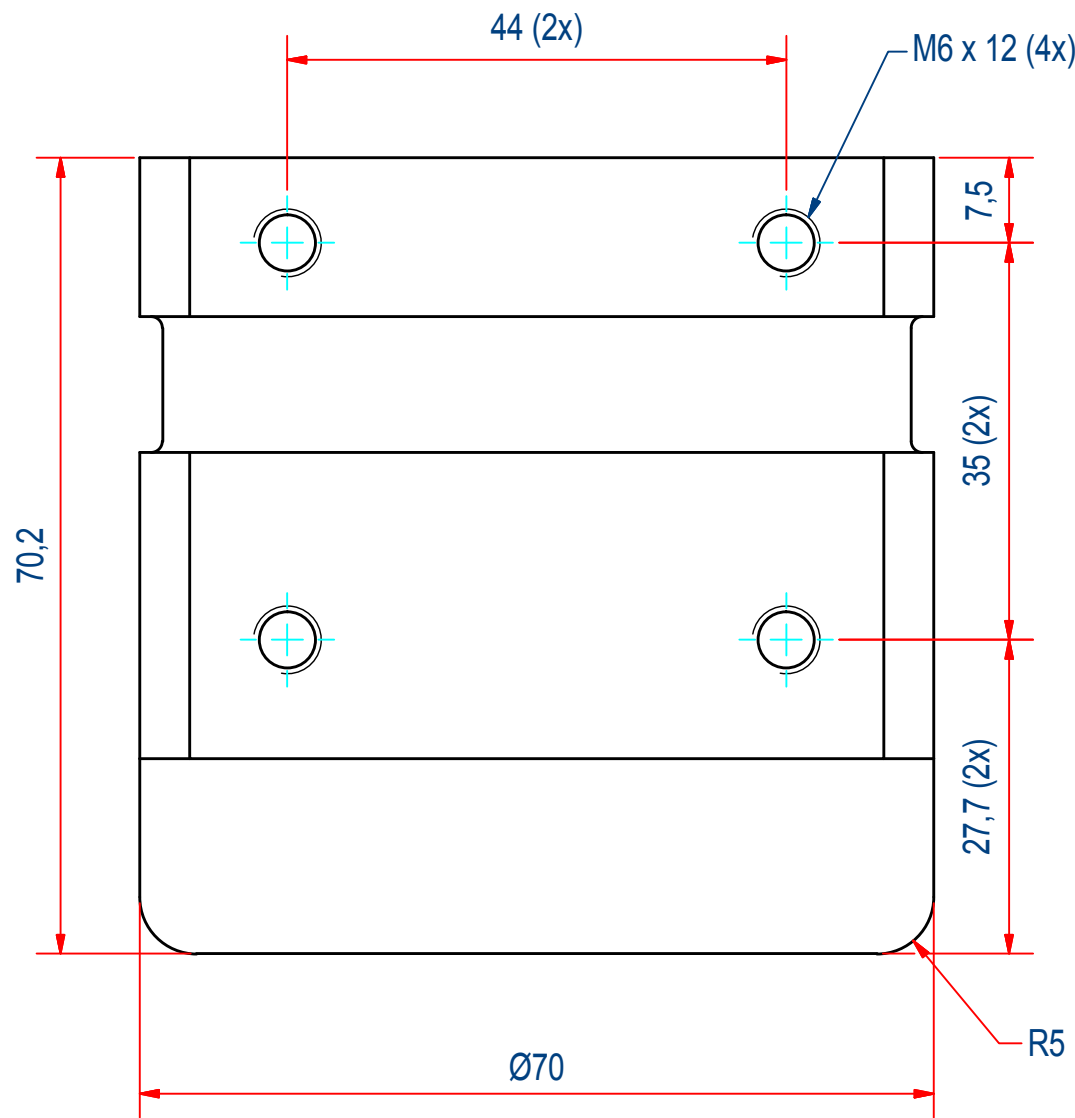
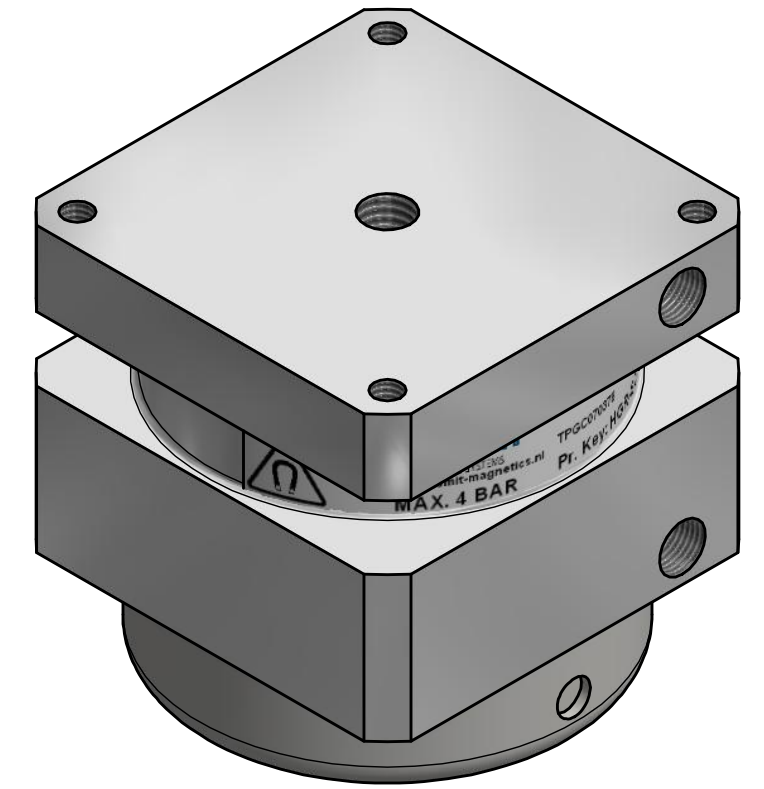
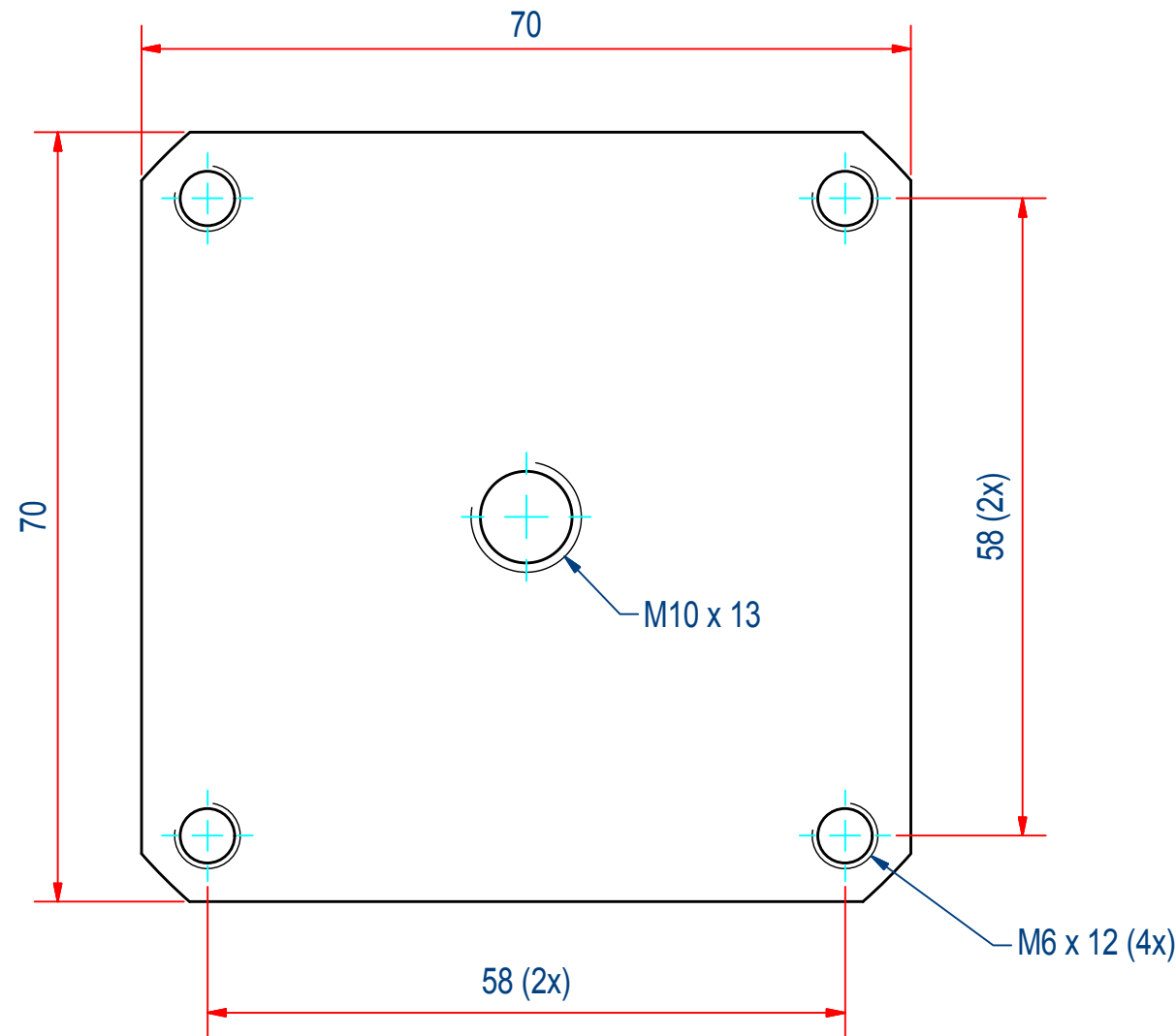

ITEM	QTY	PART NUMBER	DESCRIPTION	Dimensions
2	1	E0038041	STICKER TPGC070378	
1	1	E0016901	MOUNTING ASSY TPGC070 HT	
RAW MAT.	1			
QTY		MAT. NUMBER	MAT. DESCRIPTION	LENGTH (mm) WIDTH (mm)
Sheet: A2		Extra info:		General tolerance: ISO 2768- mK
Drawn: BS		Weight (kg): 0,8		Drawn according: ISO268; ISO1101; ISO2553
Date: 9-7-2013		Goudsmits MAGNETIC SYSTEMS		Status: Standard
Spare part: False		© All rights reserved. Reproduction is not permitted without written permission of GOUDSMIT Magnetic Systems BV		Customer reference number:
Quick search: TPGC070HT		Description: HGR-SQ-070-FL-RH-G-F		File number: E0029261 Rev: B
				Part number: TPGC070378 Rev: B

REV	DATE	BY	DESCRIPTION
-	2-7-2013	PB	NEW VAULT, NEW REVISION. NOTHING CHANGED. OLD REV WAS A
A	10-7-2014	PB	E0018884 WAS A190495.

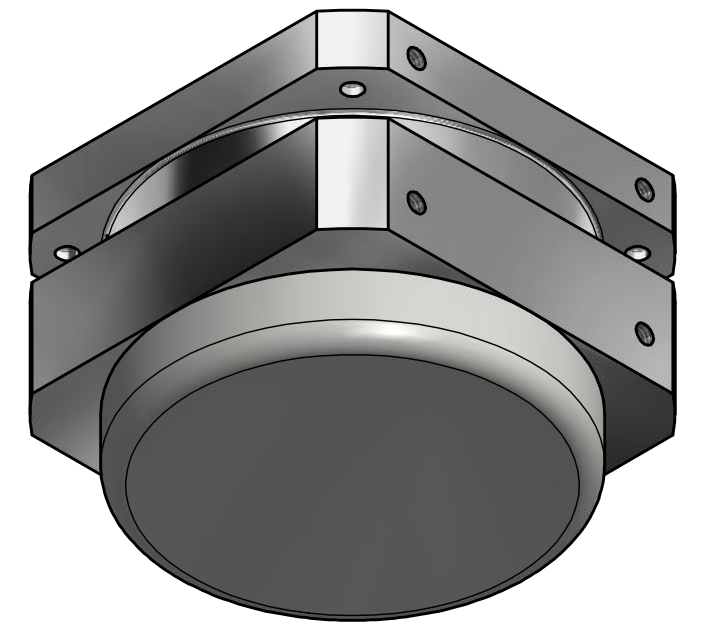
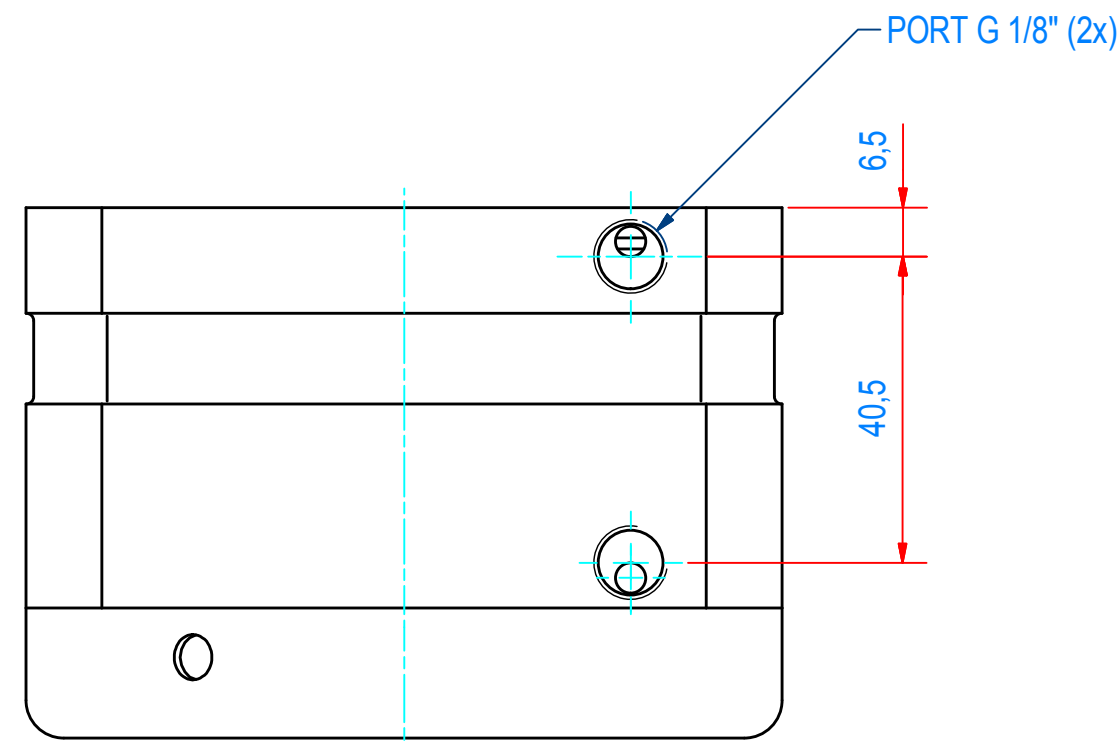
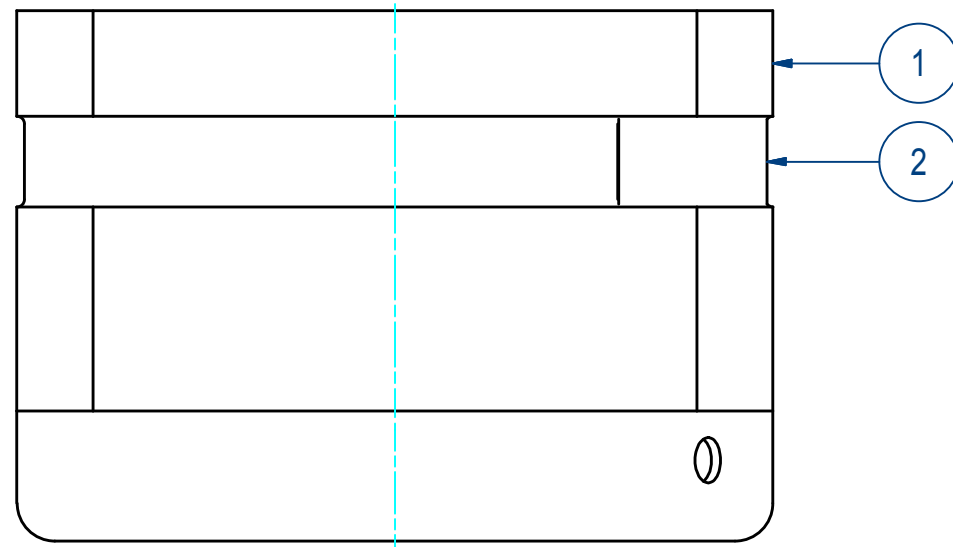
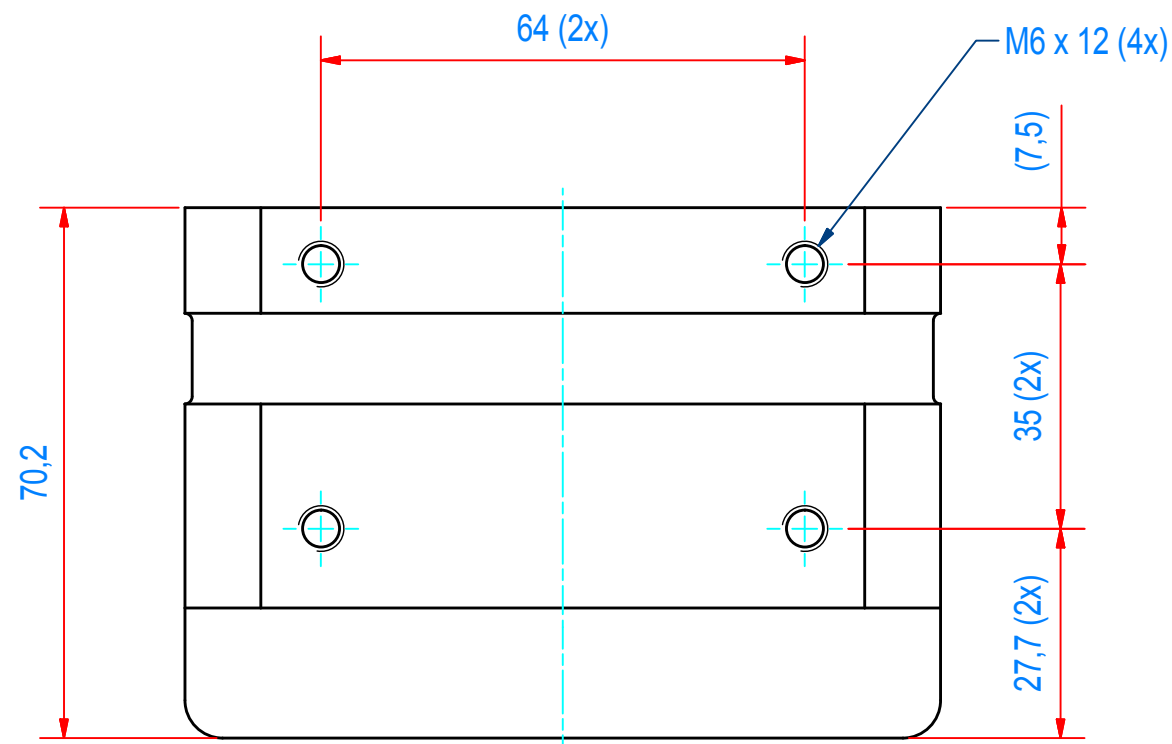
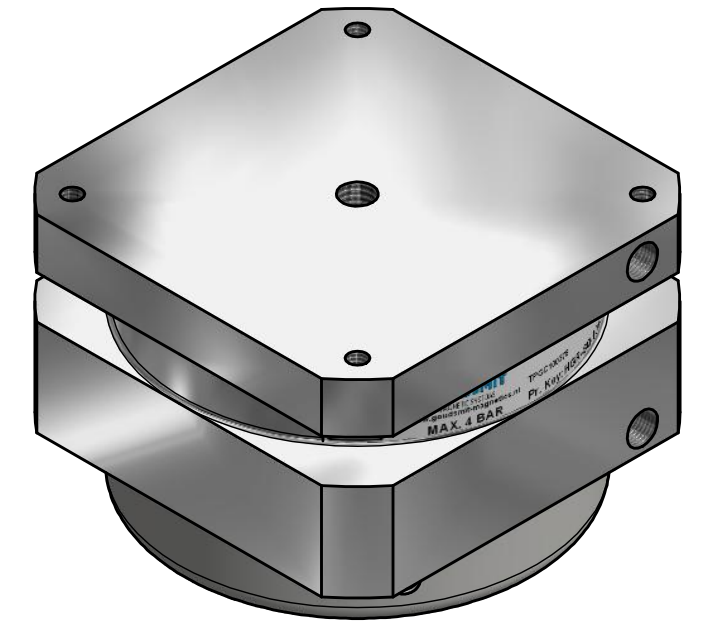
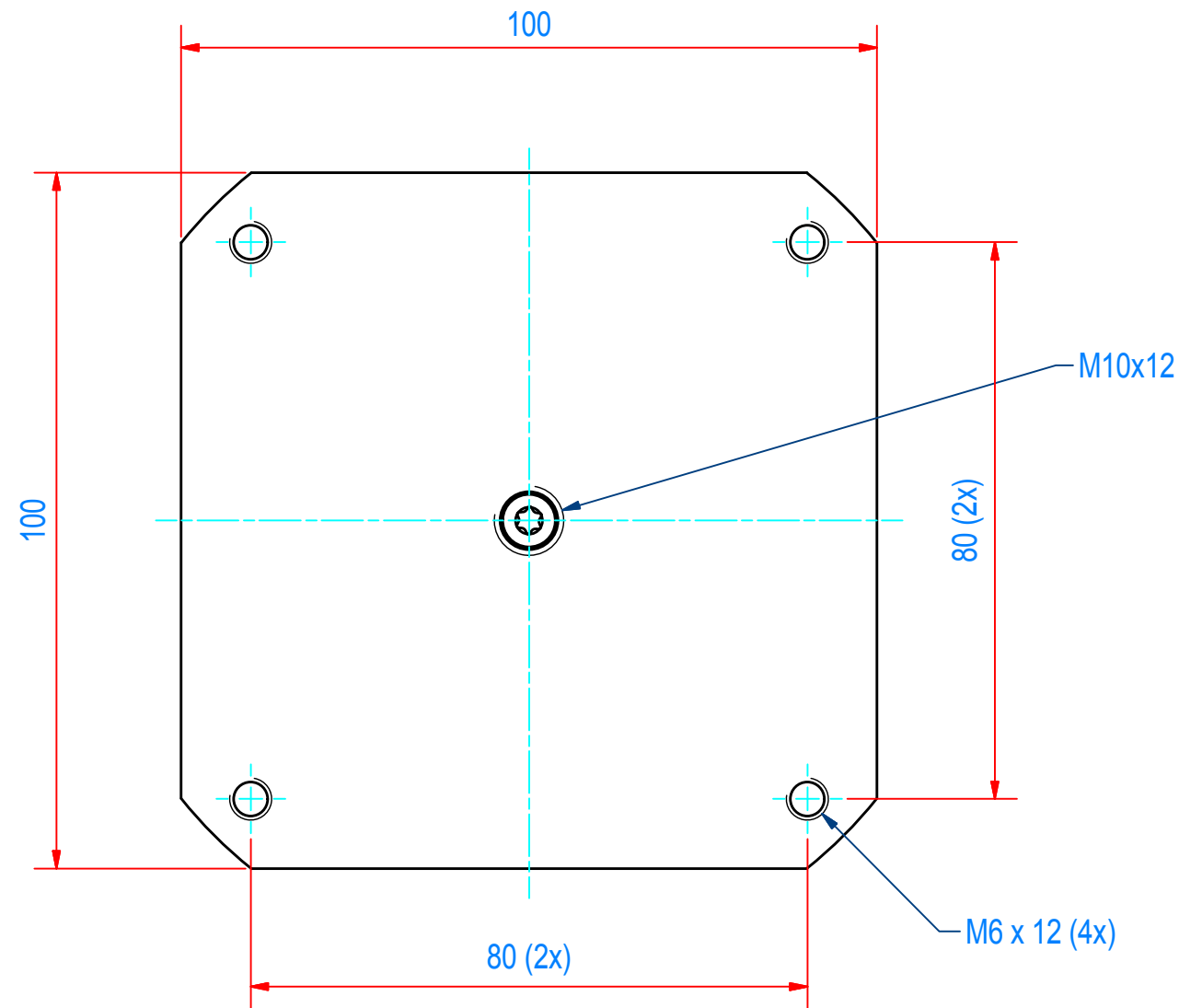

ITEM	QTY	PART NUMBER	DESCRIPTION	Dimensions
2	1	E0038043	STICKER TPGC100078	
1	1	E0018884	MOUNTING ASSY TPGC100HT	
RAW MAT.	1			
QTY		MAT. NUMBER	MAT. DESCRIPTION	LENGTH (mm) WIDTH (mm)
Sheet: A2		Extra info:		General tolerance: ISO 2768- mK
Drawn: PB		Weight (kg): 1,5		Drawn according: ISO268; ISO1101; ISO2553
Date: 2-7-2013		Status: Standard		Customer reference number:
Spare part: False		File number: TPGC100378		Rev: A
Quick search: TPGC100		Description: HGR-SQ-100-FL-RH-G-F		Part number: TPGC100378
				Rev: A



© All rights reserved. Reproduction is not permitted without written permission of GOUDSMIT Magnetic Systems BV

REV	DATE	BY	DESCRIPTION
-	10-4-2013	BS	NEW VAULT, NOTHING CHANGED, IS EQUAL TO OLD REVISION C

NEXT STEP
automation

(주)넥스텝
Tel. 053-604-3040 Fax. 053-604-3042
Web.nstep.co.kr Mob.010-4488-3040

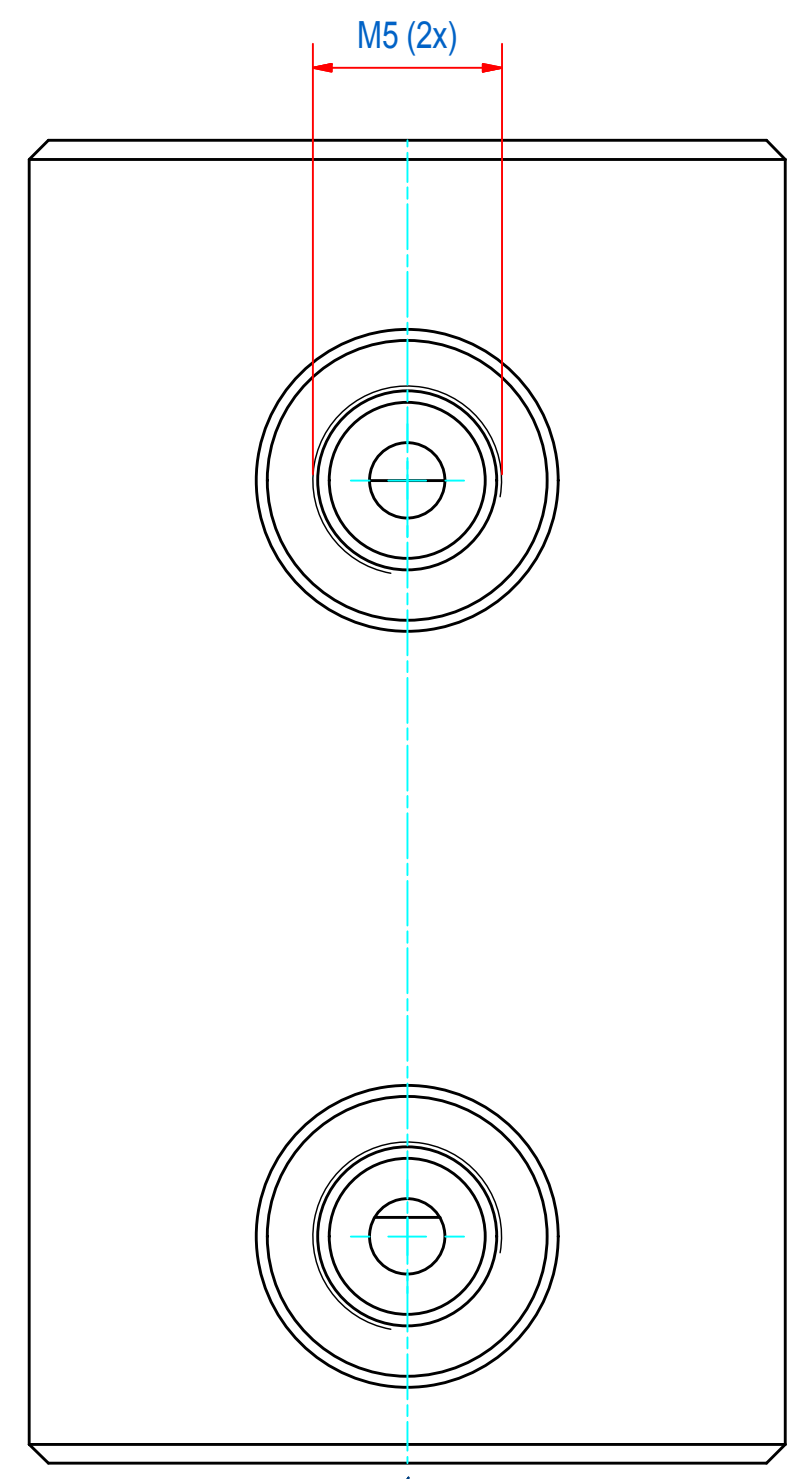
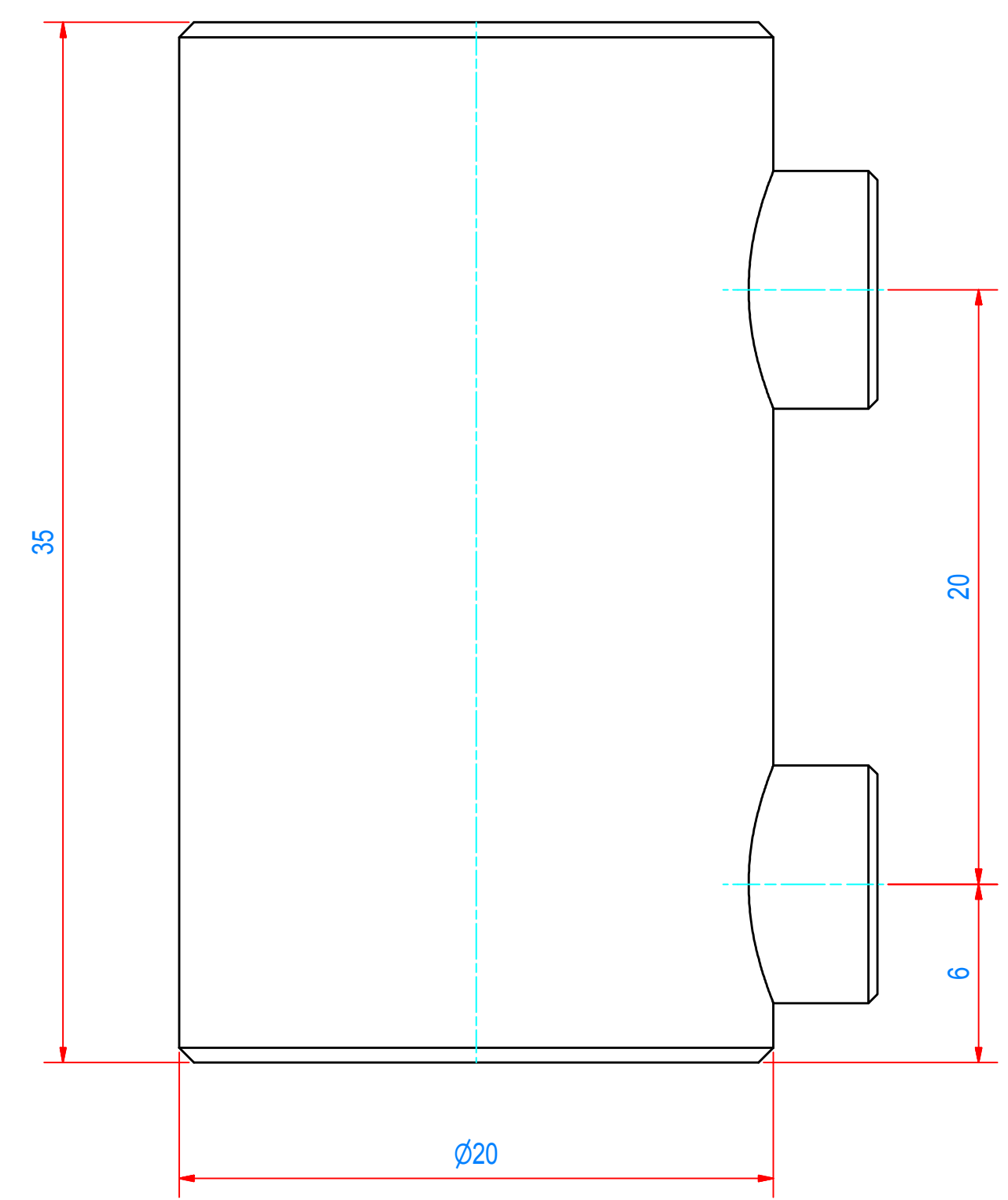
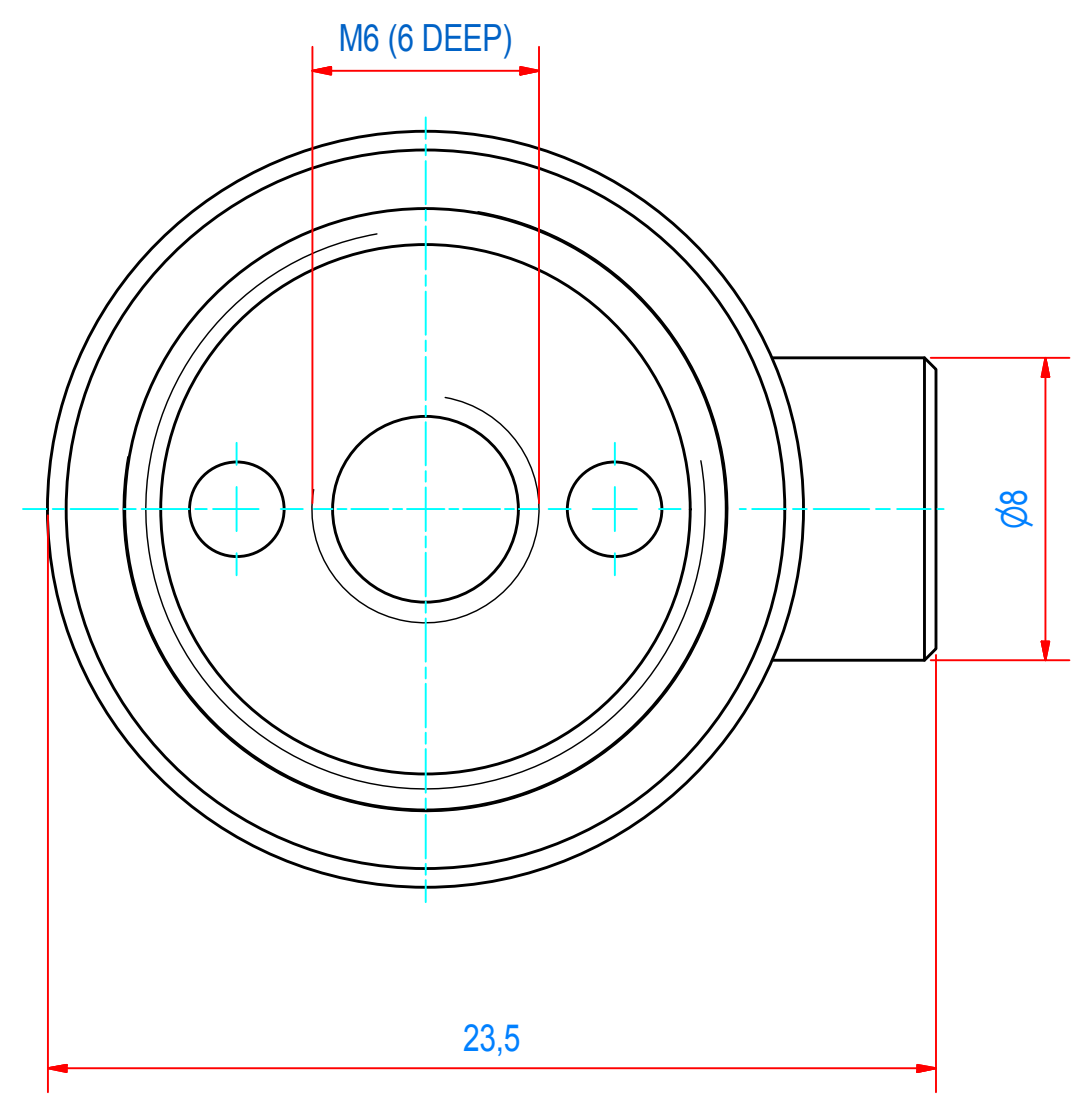

MAGNETIC SURFACE

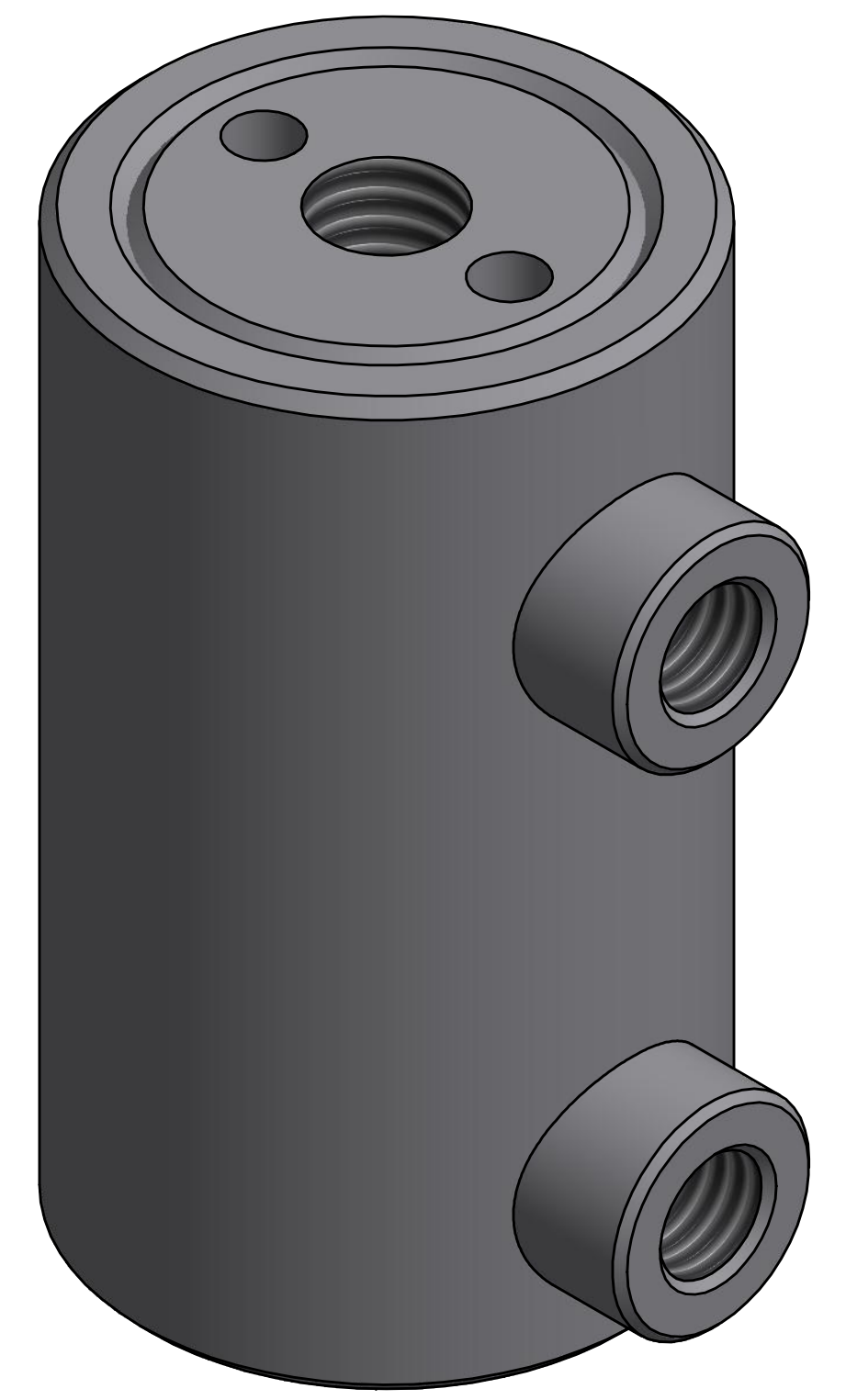

ITEM	QTY	PART NUMBER	DESCRIPTION	Dimensions	
1	1	M56335	MOUNTING ASSY TPGC020018		
RAW MAT.	1			LENGTH (mm)	WIDTH (mm)
Sheet:	A2	Extra info:	General tolerance:	ISO 2768- mK	
Drawn:	BS	Weight (kg): 0,1	Drawn according:	ISO268; ISO1101; ISO2553	
Date:	10-4-2013		Status:	Standard	
Spare part:	False		Customer reference number:		
Quick search:	TPGC020		File number:	TPGC020018	Rev: -
Description:	HGR-RO-020-FL-R-M-F			Part number:	TPGC020018

GOUDSMIT
MAGNETIC SYSTEMS

© All rights reserved. Reproduction is not permitted without written permission of GOUDSMIT Magnetic Systems BV

REV	DATE	BY	DESCRIPTION
-	9-10-2013	BS	NEW VAULT, NOTHING CHANGED, IS EQUAL TO OLD REVISION B

NEXT STEP
automation

(주)넥스텝
Tel. 053-604-3040 Fax. 053-604-3042
Web.nstep.co.kr Mob.010-4488-3040

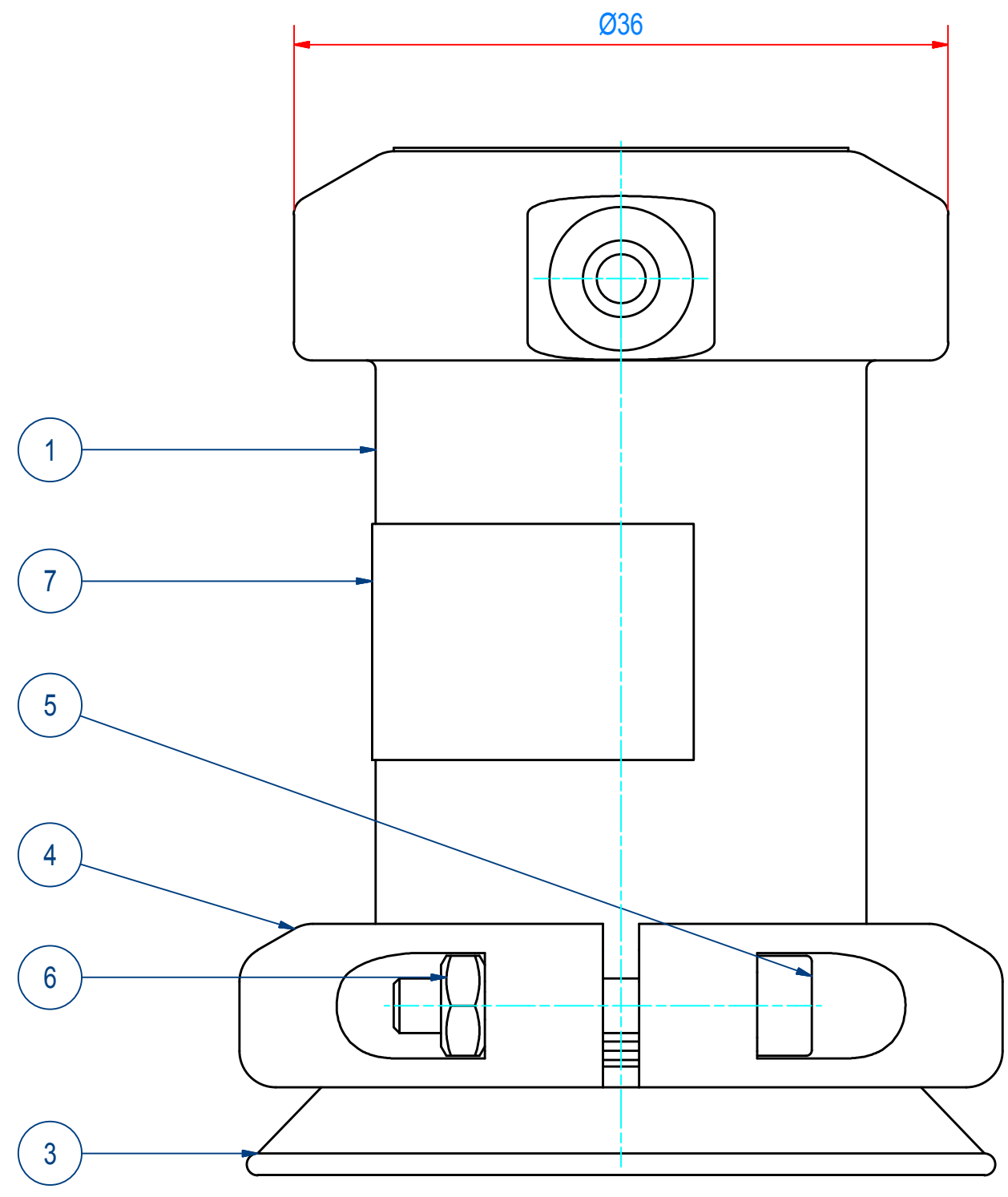
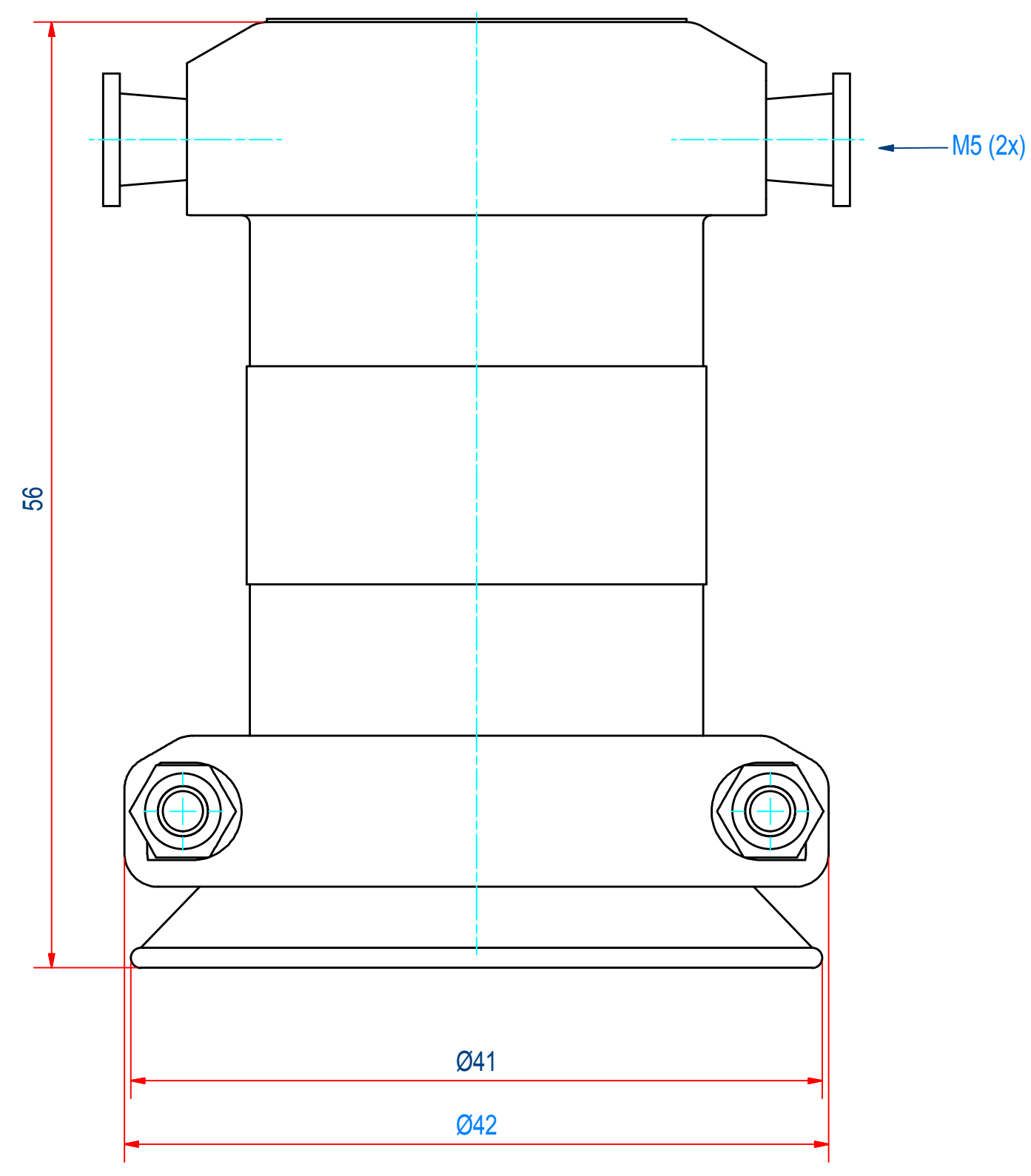
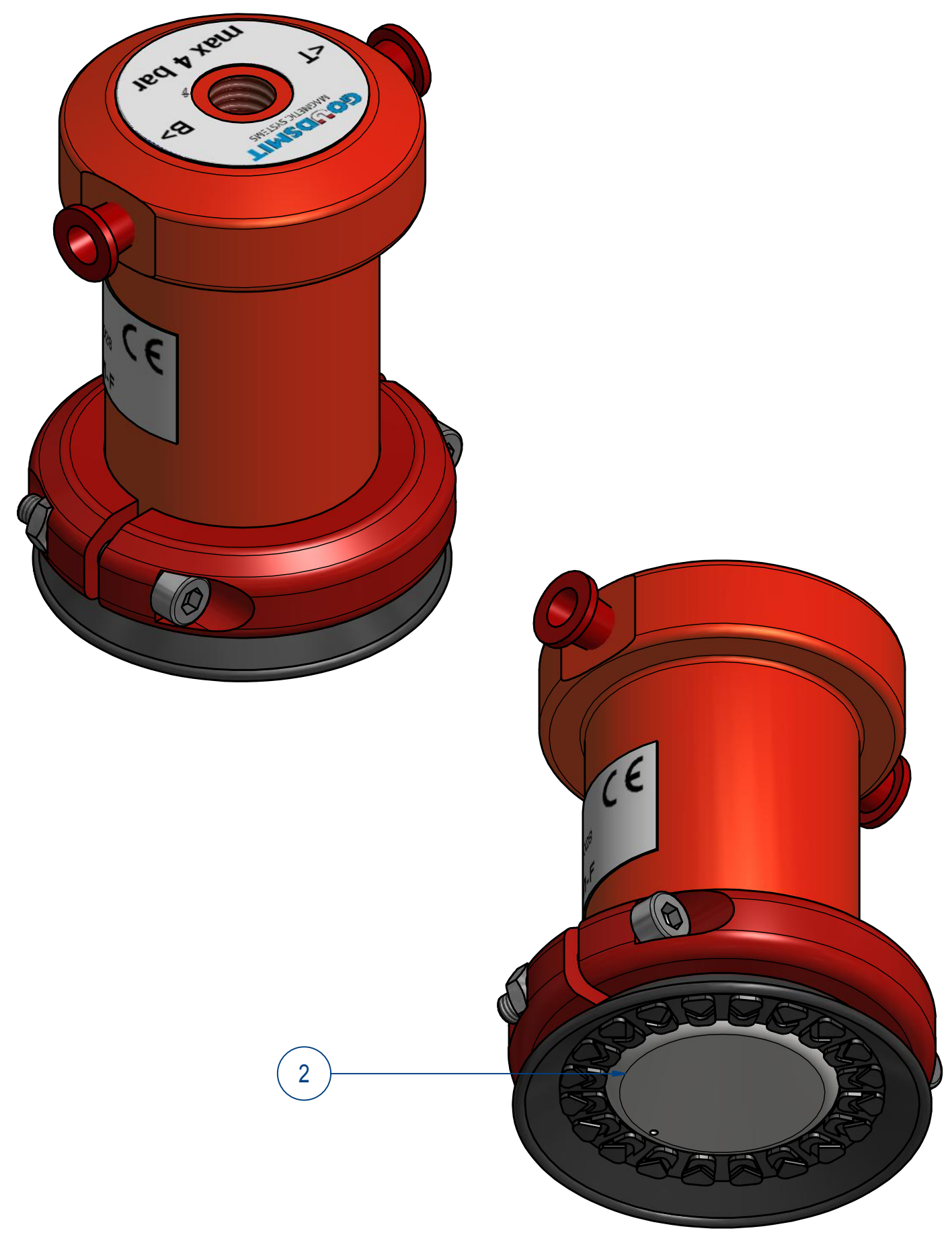
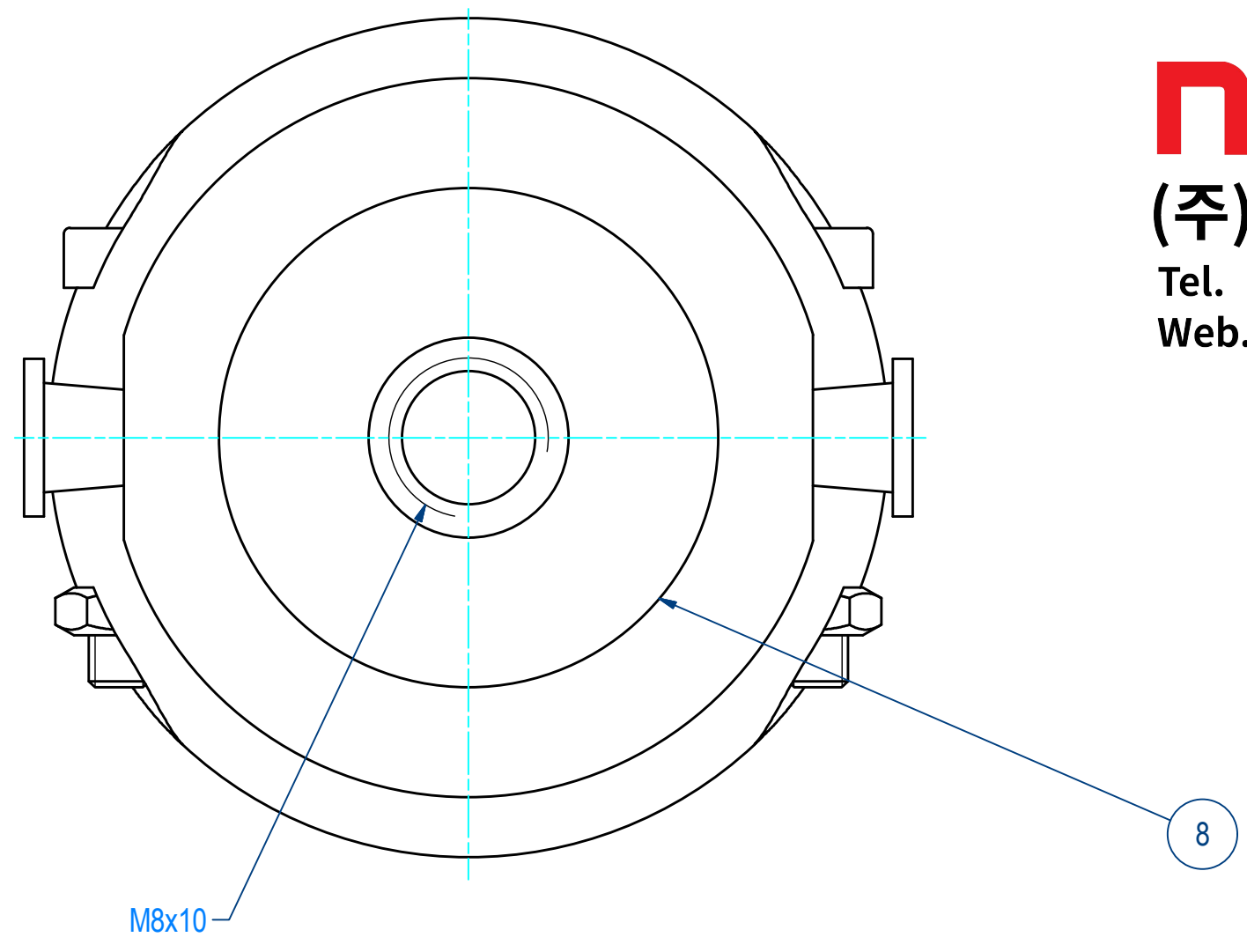

ITEM	QTY	PART NUMBER	DESCRIPTION	Dimensions
8	1	E0038131	STICKER TOP D40 d = 25 mm	
7	1	E0037940	STICKER TPMV040028	
6	2	60.0100003	NUT, HEX M3 - St8 Zn	M3
5	2	51.0103020	SCREW, HEX SH M3 x 20 - St8.8 Zn	M3 x 20
4	2	M35641	CLEAT TP040	
3	1	M35639	VACUUM PAD TPMV040	
2	1	M35648	BOTTOM COVER TP040 VACUUM HOLE	
1	1	M35647	MOUNTING ASSY TP--040028	

RAW MAT.	QTY	MAT. NUMBER	MAT. DESCRIPTION	LENGTH (mm)	WIDTH (mm)
⊕	1				

Sheet: A2	Extra info:	General tolerance: ISO 2768 - mK
Drawn: BS	Weight (kg): 0,1	Drawn according: ISO268; ISO1101; ISO2553
Date: 9-10-2013		Status: Standard
Spare part: False		Customer reference number:
Quick search: TPMV040	© All rights reserved. Reproduction is not permitted without written permission of GOUDSMIT Magnetic Systems BV	File number: TPMV040028
Description: HGC-RO-040-VR-R-M-F		Part number: TPMV040028

REV	DATE	BY	DESCRIPTION
-	18-12-2013	BS	NEW VAULT, NOTHING CHANGED, IS EQUAL TO OLD REVISION B

NEXT STEP automation

(주)넥스텝
 Tel. 053-604-3040 Fax. 053-604-3042
 Web.nstep.co.kr Mob.010-4488-3040

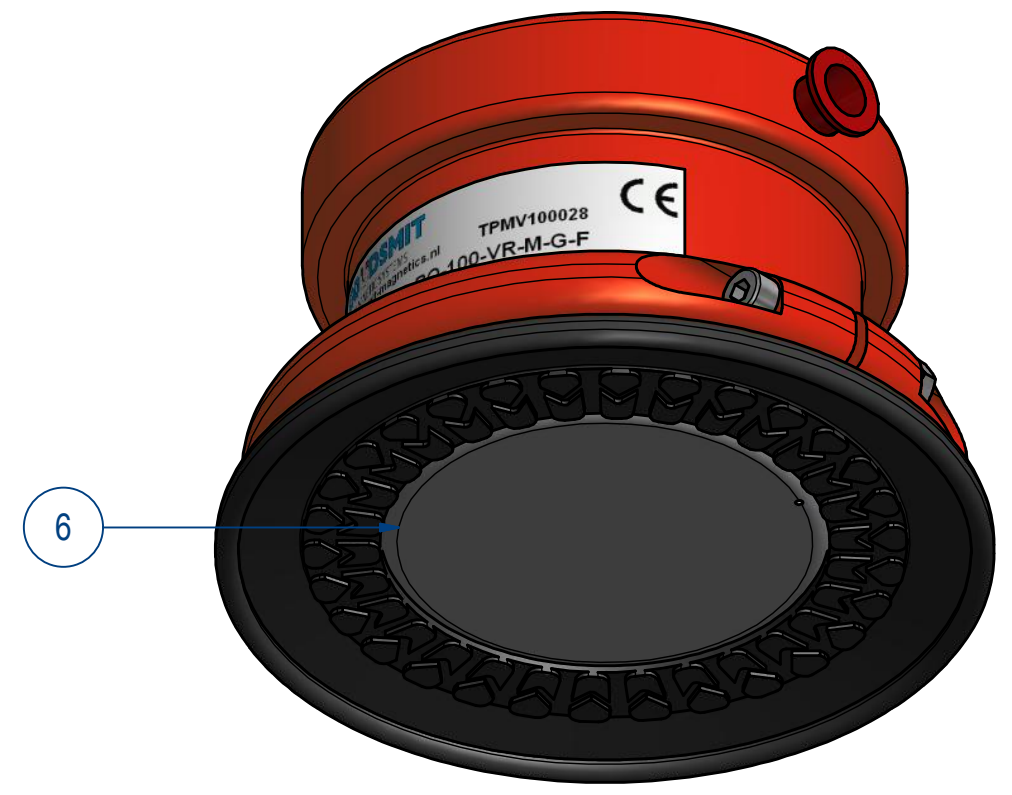
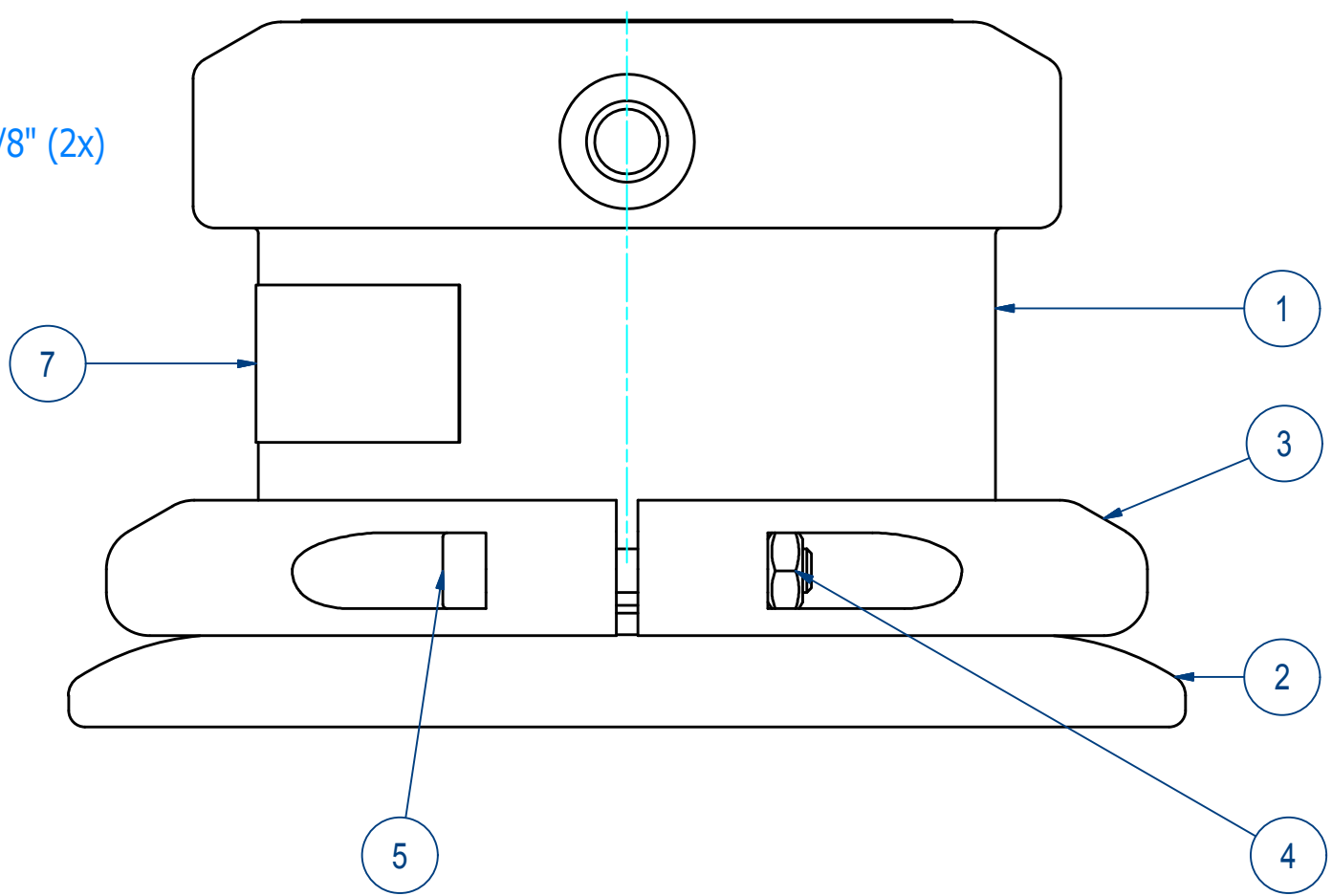
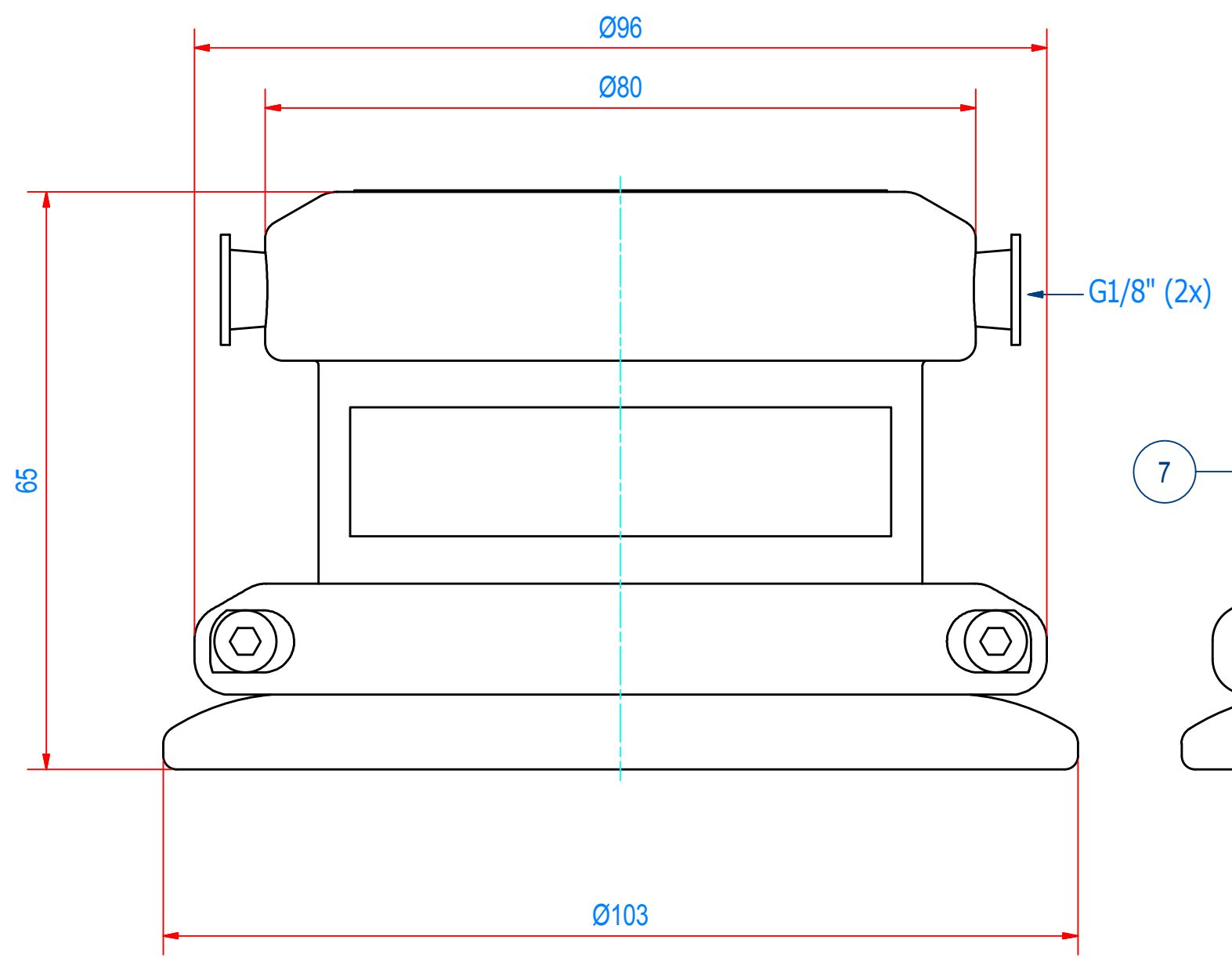
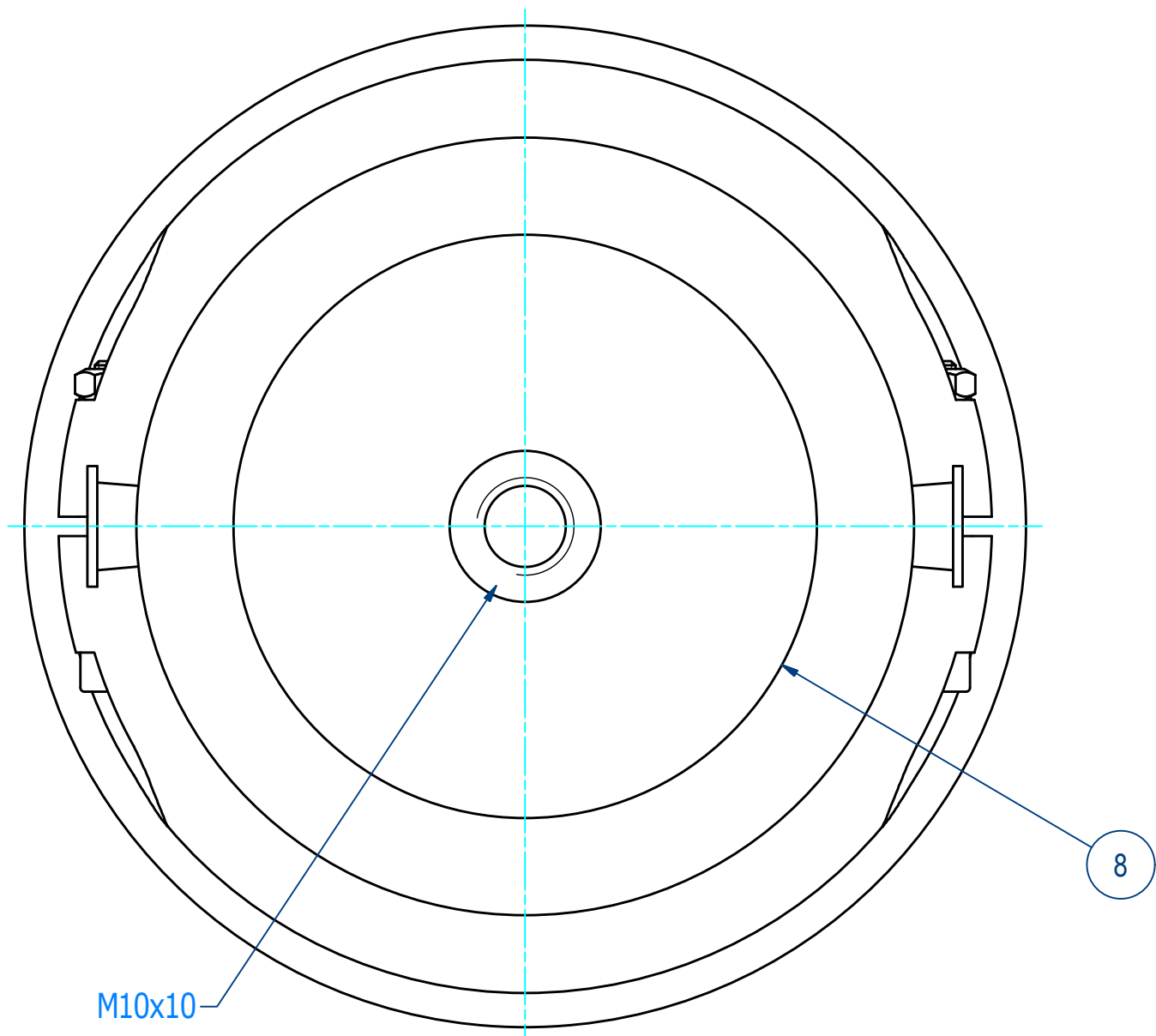

ITEM	QTY	PART NUMBER	DESCRIPTION	Dimensions
8	1	E0038135	STICKER TOP_D100 d = 60 mm	
7	1	E0037979	STICKER TPMV100028	
6	1	M35636	BOTTOM COVER TP100 VACUUM HOLE	
5	2	51.0104030	SCREW, HEX SH M4 x 30 - St8.8 Zn	M4 x 30
4	2	60.0100004	NUT, HEX M4 - St8 Zn	M4
3	2	M35605	CLEAT TP100	
2	1	M60074	VACUUM PAD DIA 100	
1	1	M35618	ASSY TP-100028	

RAW MAT.	QTY	MAT. NUMBER	MAT. DESCRIPTION	LENGTH (mm)	WIDTH (mm)
⊕	1				

Sheet: A2	Extra info:	General tolerance: ISO 2768- mK
Drawn: BS	Weight (kg): 0,7	Drawn according: ISO268; ISO1101; ISO2553
Date: 17-12-2013		Status: Standard
Spare part: False		Customer reference number:
Quick search: TPMV100	GOUDSMIT MAGNETIC SYSTEMS	File number: TPMV100028
Description: HGC-RO-100-VR-M-G-F	© All rights reserved. Reproduction is not permitted without written permission of GOUDSMIT Magnetic Systems BV	Part number: TPMV100028